

E.W.E equipment

Dewa Precision Boring Heads

FEATURES:

High Quality, excellent performance, practical design at an affordable price.

Maximum rigidity is assured even when boring bar holder is used in an offset position.

Hardened and ground adjusting screw along with our wide base design guarantees long life and trouble free use.

Ideal for CNC or manual machines.

These heads readily adapt to many different machines due to interchangeable shanks (*see overleaf for shank prices*).



SPECIFICATIONS:

MODEL	ACTUAL SIZE	O.A.L	BORING BAR HOLE SIZE	CENTRE DIST. BETWEEN HOLES	CROSS HOLE DIA.	OFFSET	T HREADED BACK	GRADS .	WEIGHT
BH50M	50MM	62MM	12MM	15MM	12MM	15MM	1-1/2" X 18	0.01MM / 0-50	0.5KG
BH75M	75MM	80MM	18MM	23MM	18MM	25MM	1-1/2" X 18	0.01MM / 0-50	2.0KG
BH100M	100MM	88MM	25MM	32MM	25MM	30MM	1-1/2" X 18	0.01MM / 0-50	4.0KG

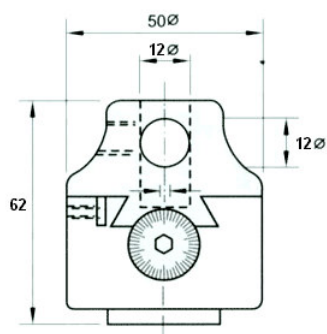

BH50M
£ 90.00

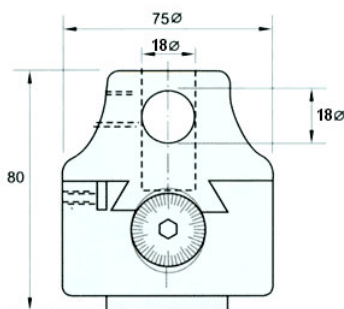

BH75M
£120.00

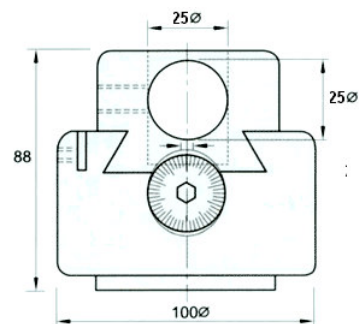

BH100M
£153.00

email: sales@ewequipment.co.uk

Tel: 0161 485 8730

Fax: 0161 485 6745

E.W.E equipment

Dewa Boring Head Shanks

1-1/2" x 18UN Thread



SHANK	PRICE
2 M/T	£25.50
3 M/T	£25.50
BT40	£87.00
DV40	£87.00
40DIN2080	£45.00
R8	£38.00
20MM STRAIGHT SHANK	£60.00
25MM STRAIGHT SHANK	£60.00

Other Shanks Available on Request

email: sales@ewequipment.co.uk

Tel: 0161 485 8730

Fax: 0161 485 6745