

# E.W. Equipment

## Tooling Catalogue



# DIN 2080 TOOLHOLDERS

11 Worcester Road, Cheadle Hulme, Cheadle, Cheshire, SK8 5NW  
Tel: 0161 485 8730 Fax: 0161 485 6745  
email: [sales@ewequipment.co.uk](mailto:sales@ewequipment.co.uk) web: [www.ewequipment.co.uk](http://www.ewequipment.co.uk)

# SECTION 1

## DIN 2080 TOOLHOLDERS

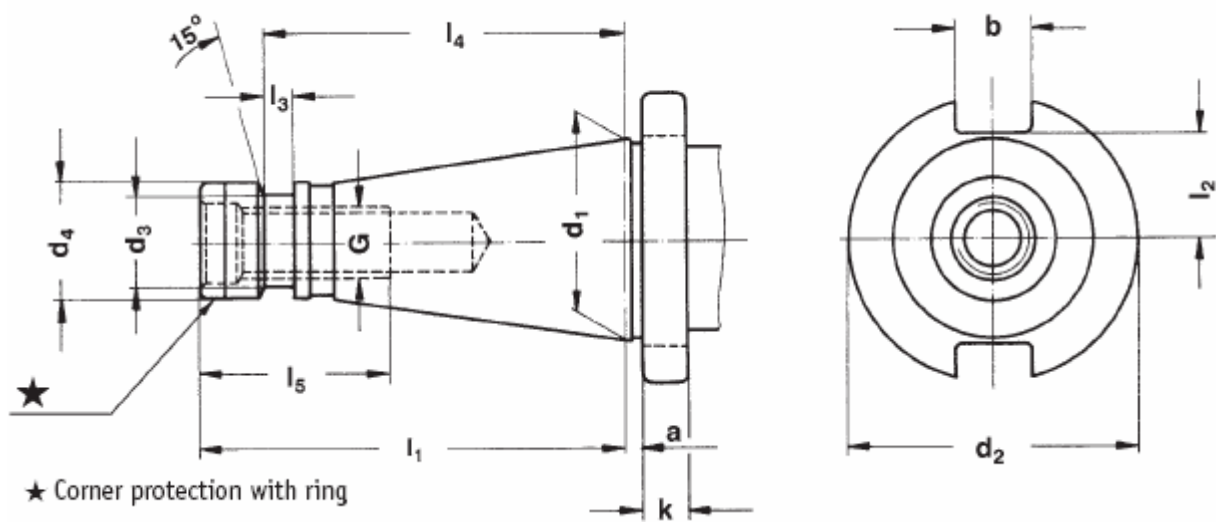

SK	d1	a	b	k	G	d2	d3	d4	l1	l2	l3	l4	l5
30	31,75	1,6	16,1	8	M12	50,0	-	17,2	68,4	16,2	-	-	24,0
40	44,45	1,6	16,1	10	M16	63,0	21,1	25,0	93,4	22,5	7,0	82,0	32,0
50	69,85	3,2	25,7	12	M24	97,5	32,0	39,2	126,8	35,3	13,0	115,0	47,0

**Material:** Case hardened steel, tensile strength in the core min. 800 N/mm<sup>2</sup>

**Execution:** Case hardened HRC 60 ± 2 (HV 700 ± 50), depth of case 0,8 mm ± 0,2 mm, black-finished

**Accuracy:** Cone angle < AT 3 for DIN 7187 and DIN 2080  
Run out between cone and holing part < 0,005 mm

# E.W. Equipment

## DIN 2080

Collet Chucks for Collets DIN 6499 ER

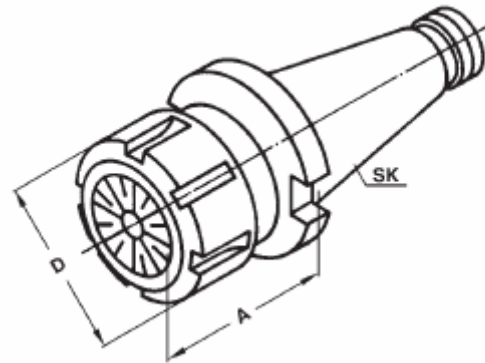

PART NUMBER	SK	CAPACITY	A	D
ISO30-ER25-050	30	ER25 2-16	50	42
ISO30-ER32-050	30	ER32 2-20	50	50
ISO40-ER25-050	40	ER25 2-16	50	42
ISO40-ER32-050	40	ER32 2-20	50	50
ISO40-ER40-080	40	ER40 3-26	80	63
ISO50-ER32-063	50	ER32 2-20	63	50
ISO50-ER40-063	50	ER40 3-26	63	63

Accessories: See Section 5



ER-COLLETS

ER-WRENCH

# E.W. Equipment

## DIN 2080

End Mill Holders DIN 6359 for Weldon Type End Mills DIN 1835-B

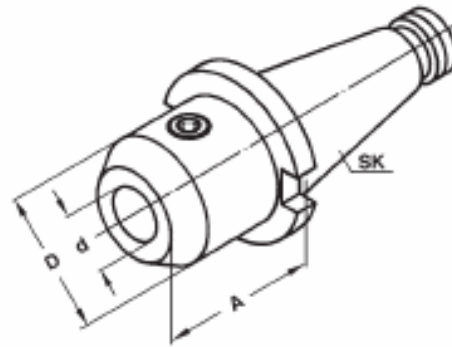

PART NUMBER	SK	d	D	A
ISO30-WE06-040	30	6	25	40
ISO30-WE08-040	30	8	28	40
ISO30-WE10-040	30	10	35	40
ISO30-WE12-040	30	12	42	40
ISO30-WE14-050	30	14	44	50
ISO30-WE16-050	30	16	48	50
ISO30-WE18-050	30	18	50	50
ISO30-WE20-063	30	20	52	63

ISO40-WE06-050	40	6	25	50
ISO40-WE08-050	40	8	28	50
ISO40-WE10-050	40	10	35	50
ISO40-WE12-050	40	12	42	50
ISO40-WE14-050	40	14	44	50
ISO40-WE16-063	40	16	48	63
ISO40-WE18-063	40	18	50	63
ISO40-WE20-063	40	20	52	63
ISO40-WE25-080	40	25	65	80
ISO40-WE32-080	40	32	72	80
ISO40-WE40-090	40	40	80	90

# E.W. Equipment

## DIN 2080

End Mill Holders DIN 6359 for Weldon Type End Mills DIN 1835-B

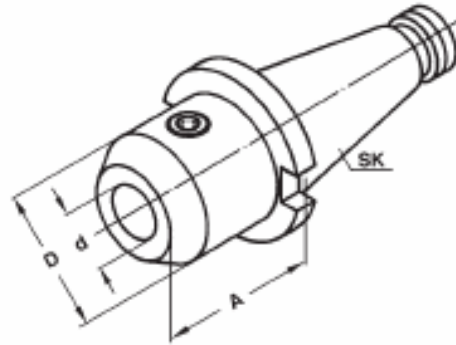

PART NUMBER	SK	d	D	A
ISO50-WE06-063	50	6	25	63
ISO50-WE08-063	50	8	28	63
ISO50-WE10-063	50	10	35	63
ISO50-WE12-063	50	12	42	63
ISO50-WE14-063	50	14	44	63
ISO50-WE16-063	50	16	48	63
ISO50-WE18-063	50	18	50	63
ISO50-WE20-063	50	20	52	63
ISO50-WE25-080	50	25	65	80
ISO50-WE32-080	50	32	72	80
ISO50-WE40-090	50	40	80	90

# E.W. Equipment

## DIN 2080

Morse Taper Adaptors DIN 6383

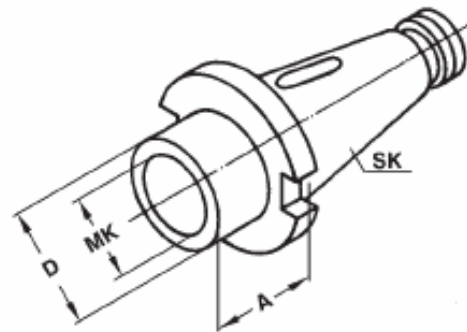

PART NUMBER	SK	MT	A	D
ISO30-MT01-050	30	1	50	25
ISO30-MT02-050	30	2	50	32
ISO30-MT03-075	30	3	75	40

ISO40-MT01-050	50	1	50	25
ISO40-MT02-050	50	2	50	32
ISO40-MT03-065	50	3	65	40
ISO40-MT04-095	50	4	95	48

ISO50-MT01-045	50	1	45	25
ISO50-MT02-060	50	2	60	32
ISO50-MT03-065	50	3	65	40
ISO50-MT04-070	50	4	70	48
ISO50-MT05-105	50	5	105	63

# E.W. Equipment

## DIN 2080

Combi Shell Mill Adaptors DIN 6358

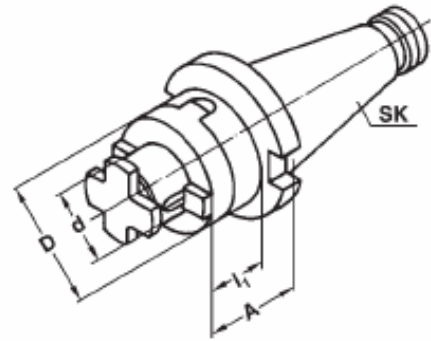

PART NUMBER	SK	d	A	l1	D
ISO30-FM16-035	30	16	35	25	32
ISO30-FM22-035	30	22	35	25	40
ISO30-FM27-035	30	27	35	25	48
ISO30-FM32-050	30	32	50	40	58

ISO40-FM16-052	40	16	52	40	32
ISO40-FM22-052	40	22	52	40	40
ISO40-FM27-052	40	27	52	40	48
ISO40-FM32-052	40	32	52	40	58
ISO40-FM40-052	40	40	52	40	70

ISO50-FM16-055	50	16	55	40	32
ISO50-FM22-055	50	22	55	40	40
ISO50-FM27-055	50	27	55	40	48
ISO50-FM32-055	50	32	55	40	58
ISO50-FM40-055	50	40	55	40	70

Accessories: See Section 5



WRENCH DIN 6368

**Includes:**  
Feather key, drive ring and draw-in bolt.

# E.W. Equipment

## DIN 2080

Shell Mill Adaptors DIN 6357 for cutters with driving slot

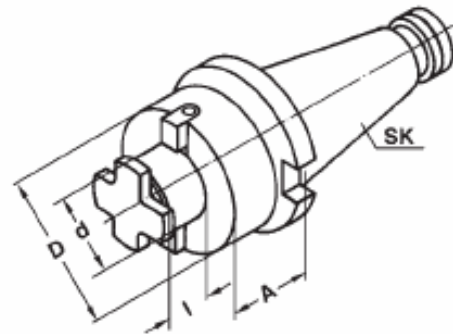

PART NUMBER	SK	d	A	I	D
ISO40-SM16-030	40	16	30	17	38
ISO40-SM22-030	40	22	30	19	48
ISO40-SM27-030	40	27	30	21	58
ISO40-SM32-030	40	32	30	24	78
ISO40-SM40-030	40	40	30	27	88
ISO50-SM16-035	50	22	35	19	48
ISO50-SM22-035	50	27	35	21	58
ISO50-SM27-040	50	32	40	24	78
ISO50-SM32-033	50	40	33	27	88
ISO50-SM40-055	50	60	55	40	129

### Includes:

Drive and cruciform screw

d = 40 & d = 60 have additional screw holes in compliance with DIN 2079

1.07

Accessories: See Section 5



WRENCH DIN 6368

# E.W. Equipment

## DIN 2080

Drill Chuck Adaptors DIN 238

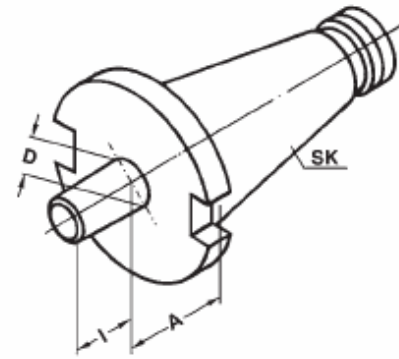

PART NUMBER	SK	D	A	I
ISO30-B12-015	30	B12	15	18.5
ISO30-B16-017	30	B16	17	24
ISO40-B12-015	40	B12	15	18.5
ISO40-B16-017	40	B16	17	24
ISO40-B18-017	40	B18	17	32
ISO50-B16-020	50	B16	20	24
ISO50-B18-020	50	B18	20	32

# E.W. Equipment

## DIN 2080

NC-Drill Chucks for left and right rotation

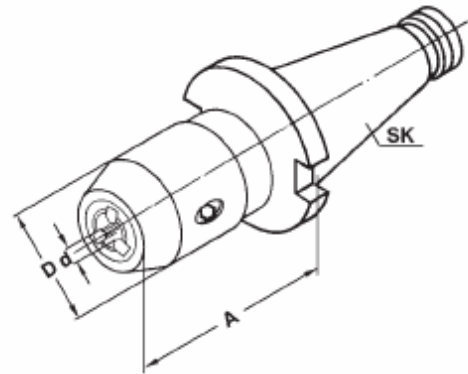

PART NUMBER	SK	d CAPACITY	A	D
ISO40-DC08-062	40	0.5 - 8	62	36
ISO40-DC13-083	40	1.0 - 13	83	50
ISO40-DC16-083	40	3.0 - 16	83	57
ISO50-DC13-100	50	1.0 - 13	100	50
ISO50-DC16-100	50	3.0 - 16	100	57

**Includes:  
Hexagon wrench.**

# E.W. Equipment

## DIN 2080 Reduction Adaptors

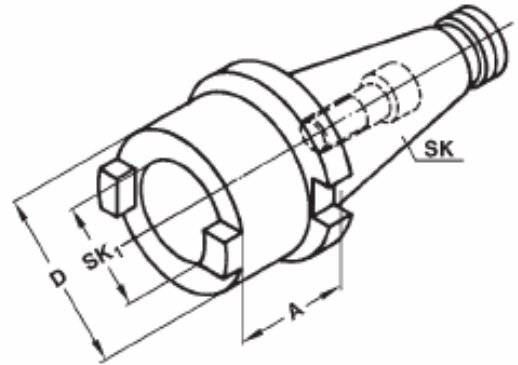

PART NUMBER	SK	SK1	A	D
ISO40-RA30-050	40	30	50	50
ISO40-RA40-100	40	40	100	063
ISO50-RA40-050	50	40	50	70
ISO50-RA40-125	50	50	125	97

# E.W. Equipment

## DIN 2080

Boring Bar Blanks for the production of special tools

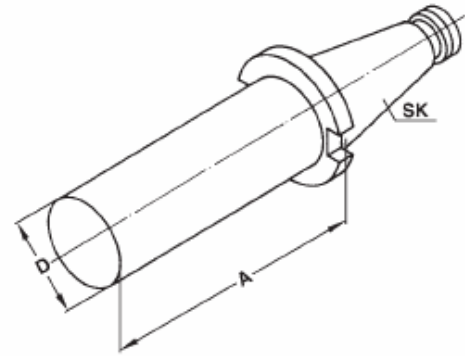

PART NUMBER	SK	D	A
ISO40-BB63-250	40	63	250
ISO50-BB97-315	50	97	315

# E.W. Equipment

## DIN 2080

Quick-Change Tapping Heads with length compensation

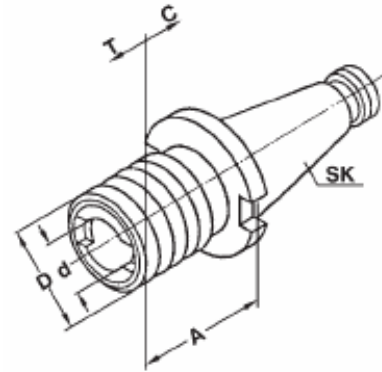

PART NUMBER	SK	CAPACITY	A	D	d	C	T
ISO30-TH01-055TC	30	M3 - M14	55	38	19	7	7
ISO30-TH02-078TC	30	M5 - M22	78	54	31	12	12
ISO40-TH01-059TC	40	M3 - M14	59	38	19	7	7
ISO40-TH02-097TC	40	M5 - M22	97	54	31	12	12
ISO40-TH03-142TC	40	M14 - M36	142	78	48	17.5	17.5
ISO50-TH01-050TC	50	M3 - M14	50	38	19	7	7
ISO50-TH02-082TC	50	M5 - M22	82	54	31	12	12
ISO50-TH03-128TC	50	M14 - M36	128	78	48	17.5	17.5

Accessories: See Section 5



TAP ADAPTORS