

E.W.Equipment

Tooling Catalogue



DIN 69871 A & AD/B TOOLHOLDERS

11 Worcester Road, Cheadle Hulme, Cheadle, Cheshire, SK8 5NW
Tel: 0161 485 8730 Fax: 0161 485 6745
email: sales@ewequipment.co.uk web: www.ewequipment.co.uk

SECTION 2

DIN 69871 AD & AD/B TOOLHOLDERS

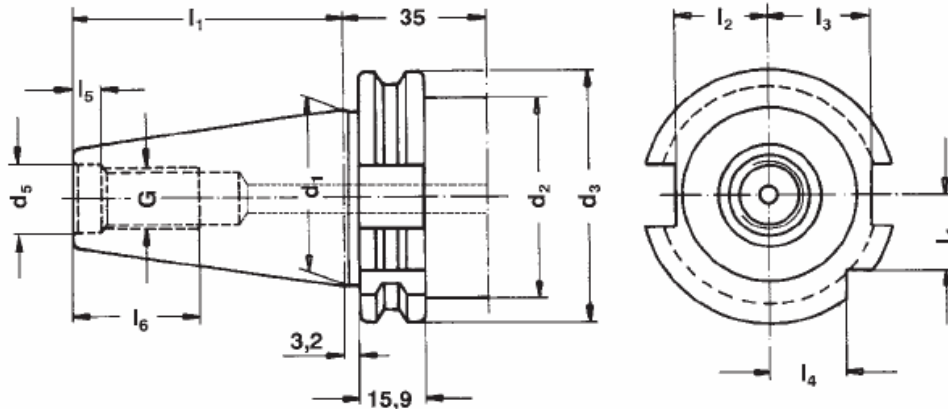

Pre-balanced G6,3 8000 min -1
G2,5 Fine Balancing available at extra cost

SK	d1	G	d5	d2	d3	l1	l2	l3	l4	l5	l6	d6	e
30	31,75	M12	13	45	50,00	47,80	16,4	19,0	15,0	5,5	24	M4	21
40	44,45	M16	17	50	63,55	68,40	22,8	25,0	18,5	8,2	32	M4	27
50	69,85	M24	25	80	97,50	101,75	35,5	37,7	30,0	11,5	47	M6	42

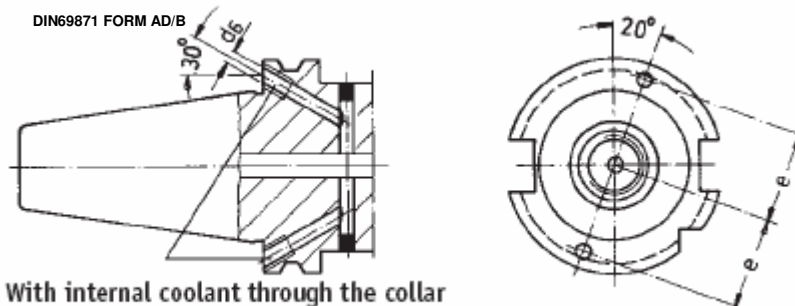

With internal coolant through the collar
Delivered with headless screws in closed position

- Material:** Alloyed case hardened steel, tensile strength in the core of min. 800 N/mm²
Case hardened HRC 60 ± 2 (HV 700 ± 50), hardening depth 0,8 mm ± 0,2 mm, black-finished
- Type AD/B:** Delivery in form AD, type B closed with a releasable headless screw
- Accuracy:** Cone angle – tolerance exactness < AT 3 according to DIN 7187 and DIN 2080
Max. run out inaccuracy < 0,005 mm

2.01

E.W. Equipment

DIN 69871 AD & AD/B Collet Chucks for Collets DIN 6499 ER

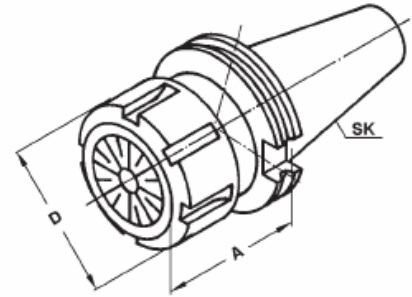

PART NUMBER	SK	FORM	CAPACITY	A	D
DV30-ER16-070	30	AD	ER16 1-10	70	32
DV30-ER16-100	30	AD	ER16 1-10	100	32
DV30-ER25-070	30	AD	ER25 2-16	70	42
DV30-ER25-100	30	AD	ER25 2-16	100	42
DV30-ER32-070	30	AD	ER32 2-20	70	50
DV30-ER32-100	30	AD	ER32 2-20	100	50
DV30-ER40-070	30	AD	ER40 3-26	70	63

DV40-ER16-063	40	AD/B	ER16 1-10	63	32
DV40-ER16-100	40	AD/B	ER16 1-10	100	32
DV40-ER16-160	40	AD/B	ER16 1-10	160	32
DV40-ER25-060	40	AD/B	ER25 2-16	60	42
DV40-ER25-100	40	AD/B	ER25 2-16	100	42
DV40-ER25-160	40	AD/B	ER25 2-16	160	42
DV40-ER32-070	40	AD/B	ER32 2-20	70	50
DV40-ER32-100	40	AD/B	ER32 2-20	100	50
DV40-ER32-160	40	AD/B	ER32 2-20	160	50
DV40-ER40-080	40	AD/B	ER40 3-26	80	63
DV40-ER40-100	40	AD/B	ER40 3-26	100	63
DV40-ER40-160	40	AD/B	ER40 3-26	160	63

Accessories: See Section 5



ER-COLLETS

ER-WRENCH

E.W. Equipment

DIN 69871 AD & AD/B

End Mill Holders DIN 6359 for Weldon Type End Mills DIN 1835-B

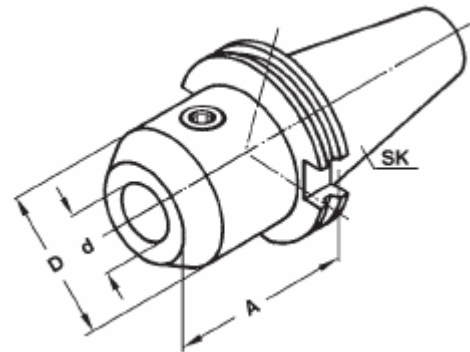

PART NUMBER	SK	FORM	d	A	D
DV30-WE06-050	30	AD	6	50	25
DV30-WE08-050	30	AD	8	50	28
DV30-WE10-050	30	AD	10	50	35
DV30-WE12-050	30	AD	12	50	42
DV30-WE14-063	30	AD	14	63	44
DV30-WE16-063	30	AD	16	63	48
DV30-WE18-063	30	AD	18	63	50
DV30-WE20-070	30	AD	20	70	52

DV40-WE06-050	40	AD/B	6	50	25
DV40-WE06-100	40	AD/B	6	100	25
DV40-WE06-160	40	AD/B	6	160	25
DV40-WE08-050	40	AD/B	8	50	28
DV40-WE08-100	40	AD/B	8	100	28
DV40-WE08-160	40	AD/B	8	160	28
DV40-WE10-050	40	AD/B	10	50	35
DV40-WE10-100	40	AD/B	10	100	35
DV40-WE10-160	40	AD/B	10	160	35
DV40-WE12-050	40	AD/B	12	50	42
DV40-WE12-100	40	AD/B	12	100	42
DV40-WE12-160	40	AD/B	12	160	42

E.W. Equipment

DIN 69871 AD/B

End Mill Holders DIN 6359 for Weldon Type End Mills DIN 1835-B

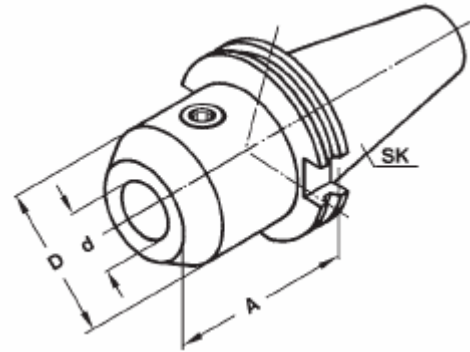

PART NUMBER	SK	d	A	D
DV40-WE14-050	40	14	50	44
DV40-WE14-100	40	14	100	44
DV40-WE14-160	40	14	160	44
DV40-WE16-035	40	16	35	45
DV40-WE16-063	40	16	63	48
DV40-WE16-100	40	16	100	48
DV40-WE16-160	40	16	160	48
DV40-WE18-063	40	18	63	50
DV40-WE18-100	40	18	100	50
DV40-WE18-160	40	18	160	50
DV40-WE20-035	40	20	35	45
DV40-WE20-063	40	20	63	52
DV40-WE20-100	40	20	100	52
DV40-WE20-160	40	20	160	52
DV40-WE25-035	40	25	35	50
DV40-WE25-100	40	25	100	65
DV40-WE25-160	40	25	160	65
DV40-WE32-065	40	32	65	50
DV40-WE32-100	40	32	100	72
DV40-WE32-160	40	32	160	72
DV40-WE40-120	40	40	120	80

E.W. Equipment

DIN 69871 AD/B

End Mill Holders DIN 6359 for Weldon Type End Mills DIN 1835-B

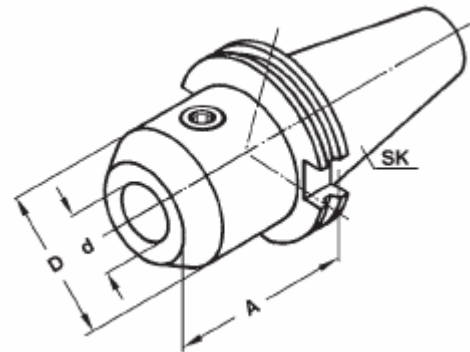

PART NUMBER	SK	d	A	D
DV50-WE06-063	50	6	63	25
DV50-WE06-100	50	6	100	25
DV50-WE06-160	50	6	160	25
DV50-WE08-063	50	8	63	28
DV50-WE08-100	50	8	100	28
DV50-WE08-160	50	8	160	28
DV50-WE10-063	50	10	63	35
DV50-WE10-100	50	10	100	35
DV50-WE10-160	50	10	160	35
DV50-WE12-063	50	12	63	42
DV50-WE12-100	50	12	100	42
DV50-WE12-160	50	12	160	42
DV50-WE14-063	50	14	63	44
DV50-WE14-100	50	14	100	44
DV50-WE14-160	50	14	160	44

E.W. Equipment

DIN 69871 AD/B

End Mill Holders DIN 6359 for Weldon Type End Mills DIN 1835-B

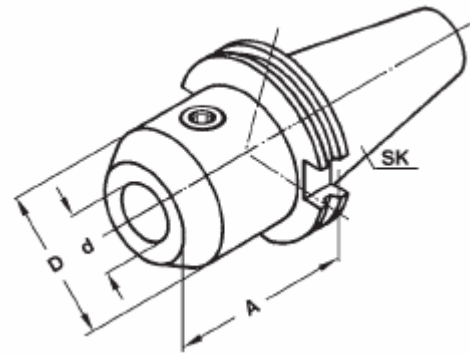

PART NUMBER	SK	d	A	D
DV50-WE16-063	50	16	63	48
DV50-WE160100	50	16	100	48
DV50-WE16-160	50	16	160	48
DV50-WE18-063	50	18	63	50
DV50-WE18-100	50	18	100	50
DV50-WE18-160	50	18	160	50
DV50-WE20-063	50	20	63	52
DV50-WE20-100	50	20	100	52
DV50-WE20-160	50	20	160	52
DV50-WE25-080	50	25	80	65
DV50-WE25-120	50	25	120	65
DV50-WE25-160	50	25	160	65
DV50-WE32-100	50	32	100	72
DV50-WE32-160	50	32	160	72
DV50-WE40-100	50	40	100	80
DV50-WE40-160	50	40	160	80

E.W. Equipment

DIN 69871 AD/B

End Mill Holders DIN 6359 with coolant channel
for Weldon Type End Mills DIN 1835-B

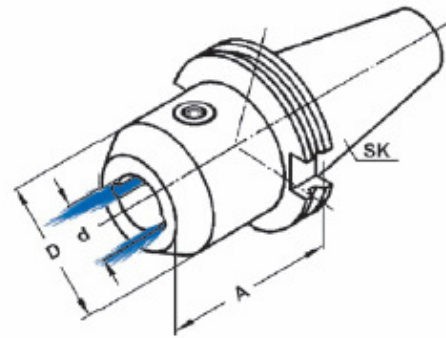

PART NUMBER	SK	d	A	D
DV40-WE06-050-CC	40	6	50	25
DV40-WE06-100-CC	40	6	100	25
DV40-WE08-050-CC	40	8	50	28
DV40-WE08-100-CC	40	8	100	28
DV40-WE10-050-CC	40	10	50	35
DV40-WE10-100-CC	40	10	100	35
DV40-WE12-050-CC	40	12	50	42
DV40-WE12-100-CC	40	12	100	42
DV40-WE14-050-CC	40	14	50	44
DV40-WE14-100-CC	40	14	100	44
DV40-WE16-063-CC	40	16	63	48
DV40-WE16-100-CC	40	16	100	48
DV40-WE18-063-CC	40	18	63	50
DV40-WE18-100-CC	40	18	100	50
DV40-WE20-063-CC	40	20	63	52
DV40-WE20-100-CC	40	20	100	52
DV40-WE25-100-CC	40	25	100	65
DV40-WE32-100-CC	40	32	100	72
DV40-WE40-120-CC	40	40	120	80

E.W. Equipment

DIN 69871 AD/B

End Mill Holders DIN 6359 with coolant channel
for Weldon Type End Mills DIN 1835-B

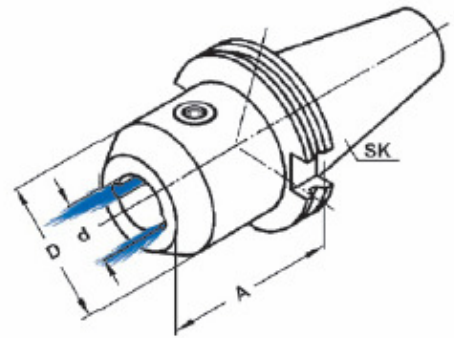

PART NUMBER	SK	d	A	D
DV50-WE06-063-CC	50	6	63	25
DV50-WE08-063-CC	50	8	63	28
DV50-WE10-063-CC	50	10	63	35
DV50-WE12-163-CC	50	12	63	42
DV50-WE14-063-CC	50	14	63	44
DV50-WE16-063-CC	50	16	63	48
DV50-WE18-063-CC	50	18	63	50
DV50-WE20-063-CC	50	20	63	52
DV50-WE25-080-CC	50	25	80	65
DV50-WE32-100-CC	50	32	100	72
DV50-WE40-100-CC	50	40	100	80

E.W. Equipment

DIN 69871 AD/B

Whistle Notch Holders DIN 6359 for End Mills DIN 1835-E

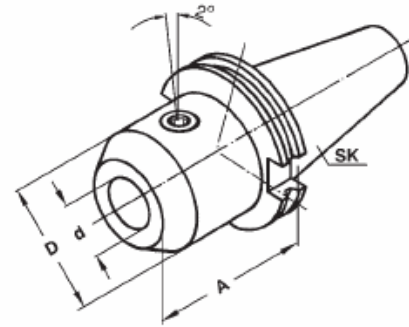

PART NUMBER	SK	d	A	D
DV40-WN06-050	40	6	50	25
DV40-WN08-050	40	8	50	28
DV40-WN10-050	40	10	50	35
DV40-WN12-050	40	12	50	42
DV40-WN14-050	40	14	50	44
DV40-WN16-063	40	16	63	48
DV40-WN18-063	40	18	63	50
DV40-WN20-063	40	20	63	52
DV40-WN25-100	40	25	100	65
DV40-WN32-100	40	32	100	72
DV40-WN40-120	40	40	120	80

DV50-WN06-063	50	6	63	25
DV50-WN08-063	50	8	63	28
DV50-WN10-063	50	10	63	35
DV50-WN12-063	50	12	63	42
DV50-WN14-063	50	14	63	44
DV50-WN16-063	50	16	63	48
DV50-WN18-063	50	18	63	50
DV50-WN20-063	50	20	63	52
DV50-WN25-080	50	25	80	65
DV50-WN32-100	50	32	100	72
DV50-WN40-100	50	40	100	80

E.W. Equipment

DIN 69871 AD & AD/B Morse Taper Adaptors DIN 6383

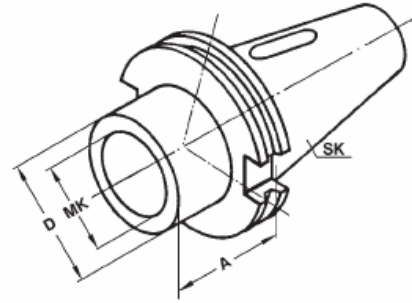

PART NUMBER	SK	FORM	MK	A	D
DV30-MT01-050	30	AD	1	50	25
DV30-MT02-065	30	AD	2	65	32
DV30-MT03-080	30	AD	3	80	40

DV40-MT01-050	40	AD/B	1	50	25
DV40-MT02-050	40	AD/B	2	50	32
DV40-MT02-117	40	AD	2	117	32
DV40-MT03-070	40	AD/B	3	70	40
DV40-MT03-133	40	AD	3	133	40
DV40-MT04-095	40	AD/B	4	95	48
DV40-MT04-156	40	AD	4	156	48

DV50-MT01-045	50	AD/B	1	45	25
DV50-MT02-060	50	AD/B	2	60	32
DV50-MT02-117	50	AD	2	117	32
DV50-MT03-065	50	AD/B	3	65	40
DV50-MT03-137	50	AD	3	137	40
DV50-MT04-095	50	AD/B	4	95	48
DV50-MT04-167	50	AD	4	167	48
DV50-MT05-105	50	AD/B	5	105	63
DV50-MT05-197	50	AD	5	197	63

E.W. Equipment

DIN 69871 AD

Combi Shell Mill Adaptors DIN 6358

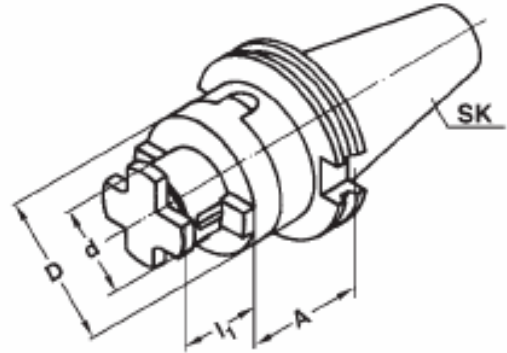

PART NUMBER	SK	d	A	l1	D
DV30-FM16-050	30	16	50	17	32
DV30-FM22-050	30	22	50	19	40
DV30-FM27-055	30	27	55	21	48
DV30-FM32-060	30	32	60	24	58

DV40-FM16-055	40	16	55	17	32
DV40-FM16-100	40	16	100	17	32
DV40-FM22-055	40	22	55	19	40
DV40-FM22-100	40	22	100	19	40
DV40-FM27-055	40	27	55	21	48
DV40-FM27-100	40	27	100	21	48
DV40-FM32-060	40	32	60	24	58
DV40-FM32-100	40	32	100	24	58
DV40-FM40-060	40	40	60	27	70
DV40-FM40-100	40	40	100	27	70

Includes:
Feather key, drive ring and draw-in bolt.

Accessories: See Section 5

2.11



WRENCH DIN 6368

E.W. Equipment

DIN 69871 AD

Combi Shell Mill Adaptors DIN 6358

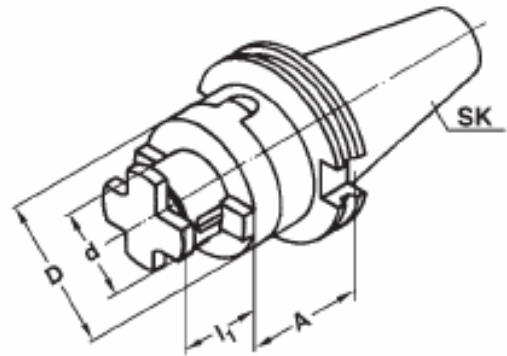

PART NUMBER	SK	d	A	l1	D
DV50-FM16-055	50	16	55	17	32
DV50-FM16-100	50	16	100	17	32
DV50-FM22-055	50	22	55	19	40
DV50-FM22-100	50	22	100	19	40
DV50-FM27-055	50	27	55	21	48
DV50-FM27-100	50	27	100	21	48
DV50-FM32-055	50	32	55	24	58
DV50-FM32-100	50	32	100	24	58
DV50-FM40-055	50	40	55	27	70
DV50-FM40-100	50	40	100	27	70

Accessories: See Section 5



WRENCH DIN 6368

Includes:
Feather key, drive ring and draw-in bolt.

E.W. Equipment

DIN 69871 AD & AD/B Shell Mill Adaptors DIN 6357

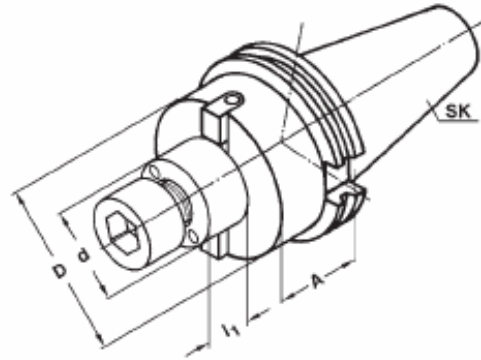

PART NUMBER	SK	FORM	d	A	l1	D
DV30-SM16-040	30	AD	16	40	17	38
DV30-SM22-040	30	AD	22	40	19	48
DV30-SM27-040	30	AD	27	40	21	58
DV30-SM32-050	30	AD	32	50	24	78

DV40-SM16-035	40	AD/B	16	35	17	38
DV40-SM22-035	40	AD/B	22	35	19	48
DV40-SM27-040	40	AD/B	27	40	21	58
DV40-SM32-050	40	AD/B	32	50	24	78
DV40-SM40-050	40	AD/B	40	50	27	88

DV50-SM22-035	50	AD/B	22	35	19	48
DV50-SM27-040	50	AD/B	27	40	21	58
DV50-SM32-050	50	AD/B	32	50	24	78
DV50-SM40-050	50	AD/B	40	50	27	88
DV50-SM60-070	50	AD/B	60	70	40	129

Includes:
Drive and cruciform screw

d = 40 & d = 60 have additional screw holes in compliance with DIN 2079

2.13

Accessories: See Section 5



WRENCH DIN 6368

E.W. Equipment

DIN 69871 A Reduction Adaptors

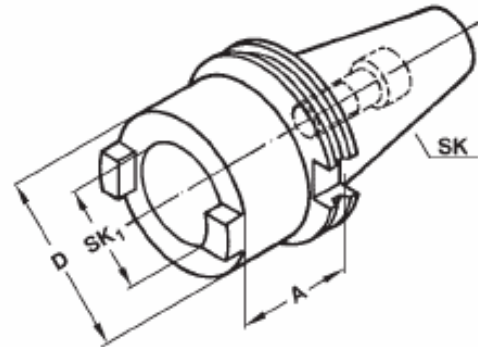

PART NUMBER	SK	SK1	A	D
DV40-RA30-050	40	30	50	50
DV40-DA40-100	40	40	100	63
DV50-RA40-070	50	40	70	70
DV50-RA50-120	50	50	120	97

Includes:
Built in screw for shortened taper tools
& additional screw for DIN 2080 tools.

E.W. Equipment

DIN 69871 A

Boring Bar Blanks for the production of special tools

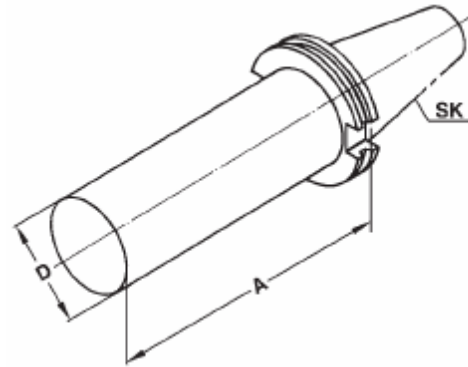

PART NUMBER	SK	D	A
DV40-BB63-250	40	63	250
DV50-BB97-315	50	97	315

E.W. Equipment

DIN 69871 A

Drill Chuck Adaptors DIN 238

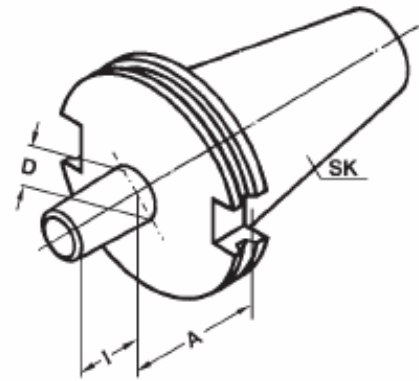

PART NUMBER	SK	D	A	I
DV30-B12-015	30	B12	15	18.5
DV30-B16-017	30	B16	17	24
DV40-B12-015	40	B12	15	18.5
DV40-B16-017	40	B16	17	24
DV40-B18-017	40	B18	17	32
DV50-B16-020	50	B16	20	24
DV50-B18-020	50	B18	20	32

E.W. Equipment

DIN 69871 A & AD/B NC-Drill Chucks for left and right rotation

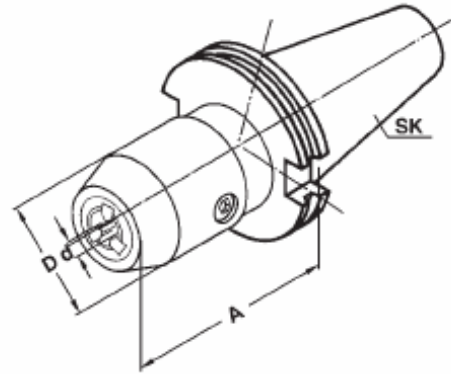

PART NUMBER	SK	FORM	d CAPACITY	A	D
DV30-DC08-070A	30	A	0.5 - 8	70	36
DV30-DC13-111A	30	A	1.0 - 13	111	50

DV40-DC08-070A	40	A	0.5 - 8	70	36
DV40-DC13-090A	40	A	1.0 - 13	90	50
DV40-DC16-090A	40	A	3.0 - 16	90	57
DV40-DC08-070B	40	AD/B	0.5 - 8	70	36
DV40-DC13-090B	40	AD/B	1.0 - 13	90	50
DV40-DC16-090B	40	AD/B	3.0 - 16	90	57

DV50-DC13-106A	50	A	1.0 - 13	106	50
DV50-DC16-106A	50	A	3.0 - 16	106	57
DV50-DC13-106B	50	AD/B	1.0 - 13	106	50
DV50-DC16-106B	50	AD/B	3.0 - 16	106	57

**Includes:
Hexagon wrench.**

E.W. Equipment

DIN 69871 A

Quick-Change Tapping Heads with length compensation

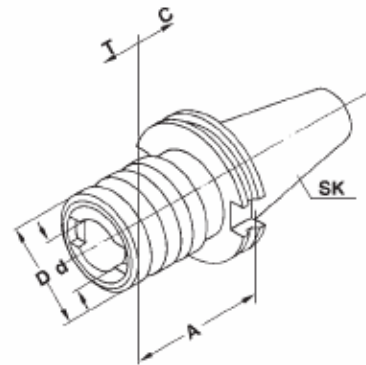

PART NUMBER	SK	CAPACITY	A	D	d	C	T
DV30-TH01-065TC	30	M3 - M14	65	38	19	7	7
DV30-TH02-103TC	30	M5 - M22	103	54	31	12	12
DV40-TH01-059TC	40	M3 - M14	59	38	19	7	7
DV40-TH02-097TC	40	M5 - M22	97	54	31	12	12
DV40-TH03-134TC	40	M14 - M36	134	78	48	17.5	17.5
DV50-TH01-050TC	50	M3 - M14	50	38	19	7	7
DV50-TH02-082TC	50	M5 - M22	82	54	31	12	12
DV50-TH03-134TC	50	M14 - M36	134	78	48	17.5	17.5

Accessories: See Section 5



TAP ADAPTORS

E.W. Equipment

DIN 69871 A

Quick-Change Tapping Heads without length compensation (Rigid)

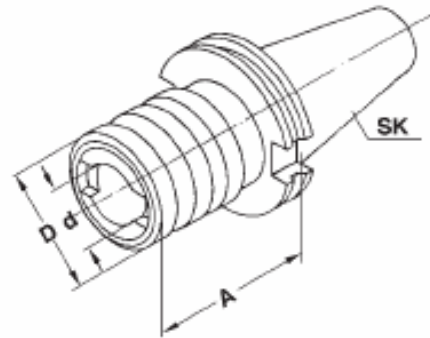

PART NUMBER	SK	CAPACITY	A	D	d
DV30-TH01-058RG	30	M3 - M14	58	38	19
DV30-TH02-093RG	30	M5 - M22	93	54	31
DV40-TH01-062RG	40	M3 - M14	62	38	19
DV40-TH02-095RG	40	M5 - M22	95	54	31
DV40-TH03-117RG	40	M14 - M36	117	78	48
DV50-TH01-060RG	50	M3 - M14	60	38	19
DV50-TH02-085RG	50	M5 - M22	85	54	31
DV50-TH03-117RG	50	M14 - M36	117	78	48

Accessories: See Section 5



TAP ADAPTORS

E.W. Equipment

DIN 69871 AD/B Hydraulic Chucks

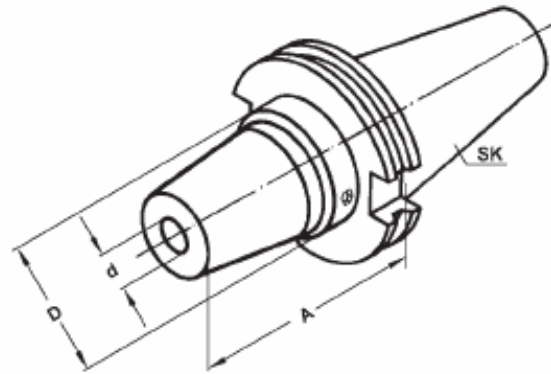

PART NUMBER	SK	d	A	D
DV50-HD06-080	50	6	80	26
DV50-HD08-080	50	8	80	28
DV50-HD10-080	50	10	80	30
DV50-HD12-080	50	12	80	32
DV50-HD14-080	50	14	80	34
DV50-HD16-080	50	16	80	38
DV50-HD18-080	50	18	80	40
DV50-HD20-080	50	20	80	42
DV50-HD25-100	50	25	100	55
DV50-HD32-100	50	32	100	63

Accessories: See Section 5

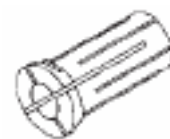

REDUCING SLEEVES