

# E.W. Equipment

## Tooling Catalogue



## DIN69893 (HSK) TOOLHOLDERS

11 Worcester Road, Cheadle Hulme, Cheadle, Cheshire, SK8 5NW  
Tel: 0161 485 8730 Fax: 0161 485 6745  
email: [sales@ewequipment.co.uk](mailto:sales@ewequipment.co.uk) web: [www.ewequipment.co.uk](http://www.ewequipment.co.uk)

# SECTION 4

## HSK-A DIN 69893-1 FORM A TOOLHOLDERS

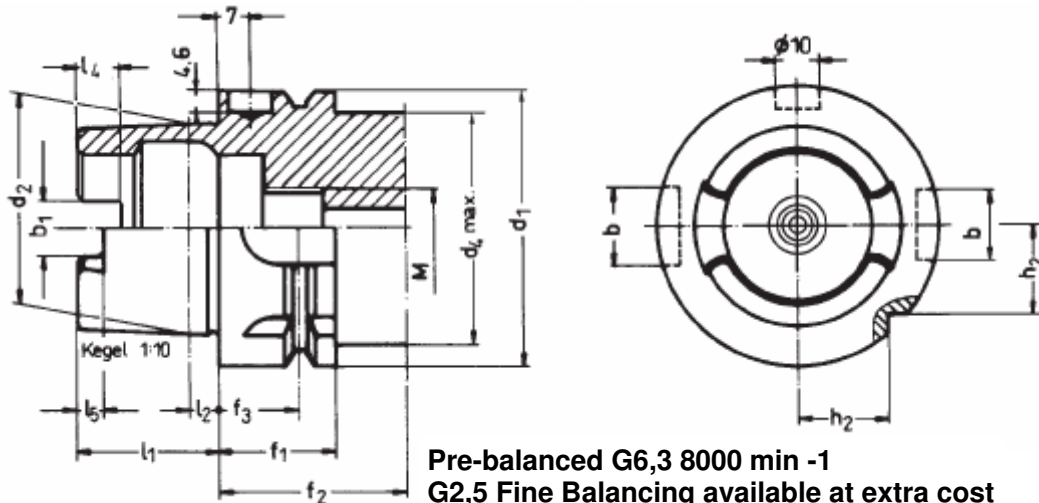

HSK-A d1	d2	d4	l1	l2	l4	l5	M	f1	f2	f3	b1	b2	b3
32	24	26	16	3,2	5,0	3,0	M10×1	20	35	16	7,05	7	9
40	30	34	20	4,0	6,0	3,5	M12×1	20	35	16	8,05	9	11
50	38	42	25	5,0	7,5	4,5	M16×1	26	42	18	10,54	12	14
63	48	53	32	6,3	10,0	6,0	M18×1	26	42	18	12,54	16	18
80	60	67	40	8,0	12,0	8,0	M20×1,5	26	42	18	16,04	18	20
100	75	85	50	10,0	15,0	10,0	M24×1,5	29	45	20	20,02	22	20

- Material:** Case hardened steel, tensile strength in the core min. 800 N/mm<sup>2</sup>
- Execution:** Case hardened HRC 60 ± 2 (HV 700 ± 50), depth of case 0,8 mm ± 0,2 mm, black-finished
- Accuracy:** Cone angle < AT 3 according to DIN 7187 and DIN 2080  
Run out between cone and holing part < 0,005 mm

# E.W. Equipment

## HSK-A DIN 6381 FORM A Collet Chucks for Collets DIN 6499 ER

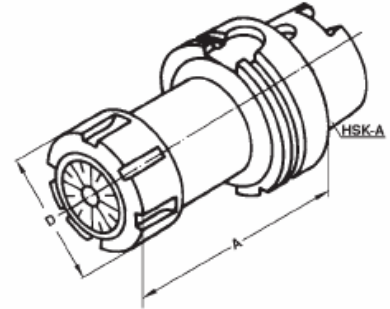

PART NUMBER	HSK	A	D
HSKA-032-ER16-080	HSK-A 32	80	32
HSKA-032-ER25-080	HSK-A 32	80	42
HSKA-040-ER16-080	HSK-A 40	80	32
HSKA-040-ER25-080	HSK-A 40	80	42
HSKA-040-ER32-100	HSK-A 40	100	50
HSKA-050-ER16-100	HSK-A 50	100	32
HSKA-050-ER25-100	HSK-A 50	100	42
HSKA-050-ER32-100	HSK-A 50	100	50
HSKA-063-ER16-100	HSK-A 63	100	32
HSKA-063-ER25-100	HSK-A 63	100	42
HSKA-063-ER25-160	HSK-A 63	160	42
HSKA-063-ER32-100	HSK-A 63	100	50
HSKA-063-ER32-160	HSK-A 63	160	50
HSKA-063-ER40-120	HSK-A 63	120	63
HSKA-063-ER40-160	HSK-A 63	160	63

Accessories: See Section 5



ER-COLLETS

ER-WRENCH

# E.W. Equipment

## HSK-A DIN 6381 FORM A Collet Chucks for Collets DIN 6499 ER

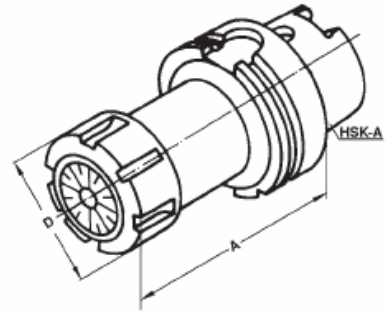

PART NUMBER	HSK	A	D
HSKA-080-ER32-100	HSK-A 80	100	50
HSKA-080-ER40-120	HSK-A 80	120	63
HSKA-100-ER25-100	HSK-A 100	100	42
HSKA-100-ER32-100	HSK-A 100	100	50
HSKA-100-ER40-120	HSK-A 100	120	63

4.03

Accessories: See Section 5



ER-COLLETS

ER-WRENCH

# E.W. Equipment

## HSK-A DIN 6381 FORM A

End Mill Holders DIN 6359 for Weldon Type End Mills DIN 1835-B

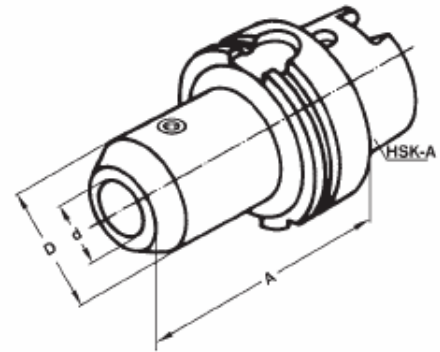

PART NUMBER	HSK	d	A	D
HSKA-032-WE06-060	HSK-A 32	6	60	25
HSKA-032-WE08-060	HSK-A 32	8	60	28
HSKA-032-WE10-065	HSK-A 32	10	65	35
HSKA-032-WE12-065	HSK-A 32	12	65	42
HSKA-040-WE06-060	HSK-A 40	6	60	25
HSKA-040-WE08-060	HSK-A 40	8	60	28
HSKA-040-WE10-060	HSK-A 40	10	60	35
HSKA-040-WE12-070	HSK-A 40	12	70	42
HSKA-040-WE16-075	HSK-A 40	16	75	48
HSKA-050-WE06-065	HSK-A 50	6	65	25
HSKA-050-WE08-065	HSK-A 50	8	65	28
HSKA-050-WE10-065	HSK-A 50	10	65	35
HSKA-050-WE12-080	HSK-A 50	12	80	42
HSKA-050-WE14-080	HSK-A 50	14	80	44
HSKA-050-WE16-080	HSK-A 50	16	80	48
HSKA-050-WE18-080	HSK-A 50	18	80	50
HSKA-050-WE20-080	HSK-A 50	20	80	52

# E.W. Equipment

## HSK-A DIN 6381 FORM A

End Mill Holders DIN 6359 for Weldon Type End Mills DIN 1835-B

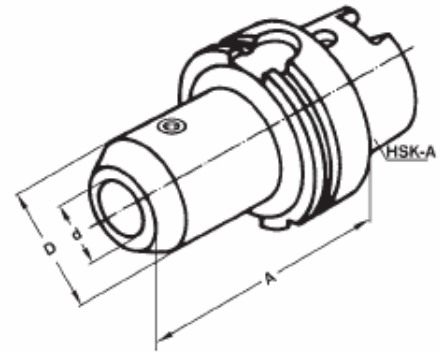

PART NUMBER	HSK	d	A	D
HSKA-063-WE06-065	HSK-A 63	6	65	25
HSKA-063-WE06-100	HSK-A 63	6	100	25
HSKA-063-WE08-065	HSK-A 63	8	65	28
HSKA-063-WE08-100	HSK-A 63	8	100	28
HSKA-063-WE10-065	HSK-A 63	10	65	35
HSKA-063-WE10-100	HSK-A 63	10	100	35
HSKA-063-WE12-080	HSK-A 63	12	80	42
HSKA-063-WE12-100	HSK-A 63	12	100	42
HSKA-063-WE14-080	HSK-A 63	14	80	44
HSKA-063-WE14-100	HSK-A 63	14	100	44
HSKA-063-WE16-080	HSK-A 63	16	80	48
HSKA-063-WE16-100	HSK-A 63	16	100	48
HSKA-063-WE18-080	HSK-A 63	18	80	50
HSKA-063-WE18-100	HSK-A 63	18	100	50
HSKA-063-WE20-080	HSK-A 63	20	80	52
HSKA-063-WE25-110	HSK-A 63	25	110	65
HSKA-063-WE32-110	HSK-A 63	32	110	72
HSKA-063-WE40-125	HSK-A 63	40	125	80

# E.W. Equipment

## HSK-A DIN 6381 FORM A

End Mill Holders DIN 6359 for Weldon Type End Mills DIN 1835-B

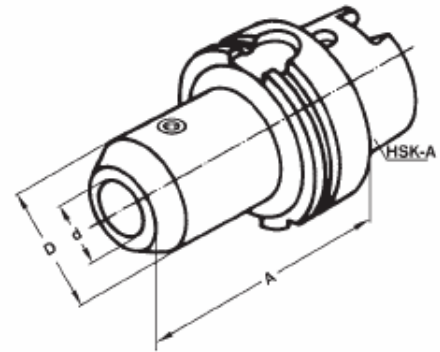

PART NUMBER	HSK	d	A	D
HSKA-080-WE06-080	HSK-A 80	6	80	25
HSKA-080-WE08-080	HSK-A 80	8	80	28
HSKA-080-WE10-080	HSK-A 80	10	80	35
HSKA-080-WE12-080	HSK-A 80	12	80	42
HSKA-080-WE14-080	HSK-A 80	14	80	44
HSKA-080-WE16-100	HSK-A 80	16	100	48
HSKA-080-WE18-100	HSK-A 80	18	100	50
HSKA-080-WE20-100	HSK-A 80	20	100	52
HSKA-080-WE25-100	HSK-A 80	25	100	65
HSKA-080-WE32-110	HSK-A 80	32	110	72

HSKA-100-WE06-080	HSK-A 100	6	80	25
HSKA-100-WE08-080	HSK-A 100	8	80	28
HSKA-100-WE10-080	HSK-A 100	10	80	35
HSKA-100-WE12-080	HSK-A 100	12	80	42
HSKA-100-WE14-080	HSK-A 100	14	80	44
HSKA-100-WE16-100	HSK-A 100	16	100	48
HSKA-100-WE18-100	HSK-A 100	18	100	50
HSKA-100-WE20-100	HSK-A 100	20	100	52
HSKA-100-WE25-100	HSK-A 100	25	100	65
HSKA-100-WE32-100	HSK-A 100	32	100	72
HSKA-100-WE40-105	HSK-A 100	40	105	80

# E.W. Equipment

## HSK-A DIN 6381 FORM A

End Mill Holders DIN 6359 with coolant channel  
for Weldon Type End Mills DIN 1835-B

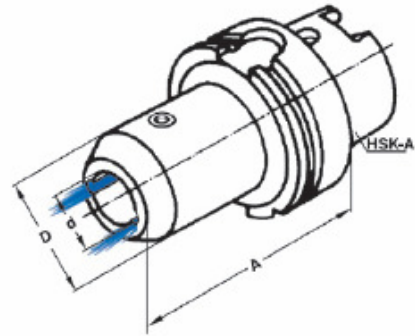

PART NUMBER	HSK	d	A	D
HSKA-032-WE06-060-CC	HSK-A 32	6	60	25
HSKA-032-WE08-060-CC	HSK-A 32	8	60	28
HSKA-032-WE10-065-CC	HSK-A 32	10	65	35
HSKA-032-WE12-065-CC	HSK-A 32	12	65	42
HSKA-040-WE06-060-CC	HSK-A 40	6	60	25
HSKA-040-WE08-060-CC	HSK-A 40	8	60	28
HSKA-040-WE10-060-CC	HSK-A 40	10	60	35
HSKA-040-WE12-070-CC	HSK-A 40	12	70	42
HSKA-040-WE16-075-CC	HSK-A 40	16	75	48
HSKA-050-WE06-065-CC	HSK-A 50	6	65	25
HSKA-050-WE08-065-CC	HSK-A 50	8	65	28
HSKA-050-WE10-065-CC	HSK-A 50	10	65	35
HSKA-050-WE12-080-CC	HSK-A 50	12	80	42
HSKA-050-WE14-080-CC	HSK-A 50	14	80	44
HSKA-050-WE16-080-CC	HSK-A 50	16	80	48
HSKA-050-WE18-080-CC	HSK-A 50	18	80	50
HSKA-050-WE20-080-CC	HSK-A 50	20	80	52

# E.W. Equipment

## HSK-A DIN 6381 FORM A

End Mill Holders DIN 6359 with coolant channel  
for Weldon Type End Mills DIN 1835-B

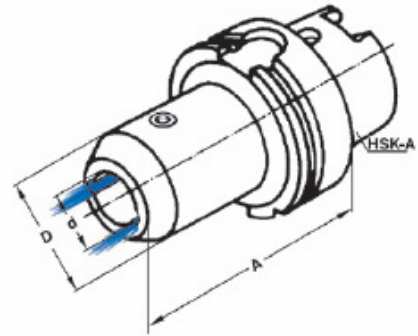

PART NUMBER	HSK	d	A	D
HSKA-063-WE06-065-CC	HSK-A 63	6	65	25
HSKA-063-WE08-065-CC	HSK-A 63	8	65	28
HSKA-063-WE10-065-CC	HSK-A 63	10	65	35
HSKA-063-WE12-080-CC	HSK-A 63	12	80	42
HSKA-063-WE14-080-CC	HSK-A 63	14	80	44
HSKA-063-WE16-080-CC	HSK-A 63	16	80	48
HSKA-063-WE18-080-CC	HSK-A 63	18	80	50
HSKA-063-WE20-080-CC	HSK-A 63	20	80	52
HSKA-063-WE32-110-CC	HSK-A 63	32	110	72
HSKA-063-WE40-125-CC	HSK-A 63	40	125	80

HSKA-080-WE06-080-CC	HSK-A 80	6	80	25
HSKA-080-WE08-080-CC	HSK-A 80	8	80	28
HSKA-080-WE10-080-CC	HSK-A 80	10	80	35
HSKA-080-WE12-080-CC	HSK-A 80	12	80	42
HSKA-080-WE14-080-CC	HSK-A 80	14	80	44
HSKA-080-WE16-100-CC	HSK-A 80	16	100	48
HSKA-080-WE18-100-CC	HSK-A 80	18	100	50
HSKA-080-WE20-100-CC	HSK-A 80	20	100	52
HSKA-080-WE25-100-CC	HSK-A 80	25	100	65
HSKA-080-WE32-110-CC	HSK-A 80	32	110	72

# E.W. Equipment

## HSK-A DIN 6381 FORM A

Combi Shell Mill Adaptors DIN 6358

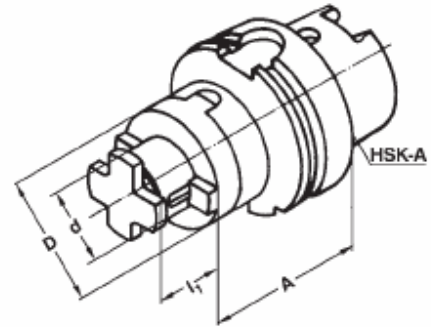

PART NUMBER	HSK	d	A	l1	D
HSKA-032-FM16-055	HSK-A 32	16	55	17	32
HSKA-032-FM22-055	HSK-A 32	22	55	19	40
HSKA-032-FM27-065	HSK-A 32	27	65	21	48
HSKA-040-FM16-050	HSK-A 40	16	50	17	32
HSKA-040-FM22-050	HSK-A 40	22	50	19	40
HSKA-040-FM27-065	HSK-A 40	27	65	21	48
HSKA-050-FM16-050	HSK-A 50	16	50	17	32
HSKA-050-FM22-050	HSK-A 50	22	50	19	40
HSKA-050-FM27-065	HSK-A 50	27	65	21	48
HSKA-050-FM32-065	HSK-A 50	32	65	24	58

Accessories: See Section 5



WRENCH DIN 6368

# E.W. Equipment

## HSK-A DIN 6381 FORM A Combi Shell Mill Adaptors DIN 6358

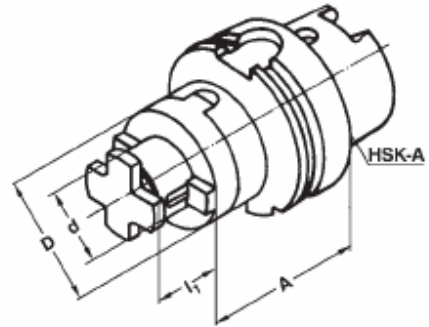

PART NUMBER	HSK	d	A	l1	D
HSKA-063-FM16-060	HSK-A 63	16	60	17	32
HSKA-063-FM16-100	HSK-A 63	16	100	17	32
HSKA-063-FM22-060	HSK-A 63	22	60	19	40
HSKA-063-FM22-100	HSK-A 63	22	100	19	40
HSKA-063-FM27-060	HSK-A 63	27	60	21	48
HSKA-063-FM27-100	HSK-A 63	27	100	21	48
HSKA-063-FM32-060	HSK-A 63	32	60	24	58
HSKA-063-FM32-100	HSK-A 63	32	100	24	58
HSKA-063-FM40-070	HSK-A 63	40	70	27	70
HSKA-080-FM16-060	HSK-A 80	16	60	17	32
HSKA-080-FM22-060	HSK-A 80	22	60	19	40
HSKA-080-FM27-060	HSK-A 80	27	60	21	48
HSKA-080-FM32-060	HSK-A 80	32	60	24	58
HSKA-080-FM40-070	HSK-A 80	40	70	27	70

Accessories: See Section 5



WRENCH DIN 6368

# E.W. Equipment

## HSK-A DIN 6381 FORM A Combi Shell Mill Adaptors DIN 6358

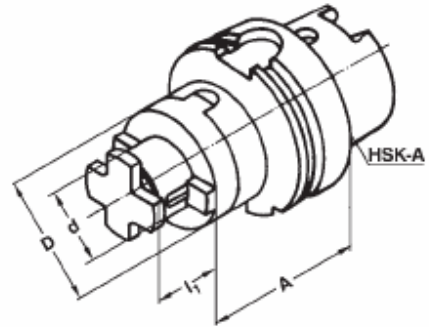

PART NUMBER	HSK	d	A	l1	D
HSKA-063-FM16-060	HSK-A 63	16	60	17	32
HSKA-063-FM16-100	HSK-A 63	16	100	17	32
HSKA-063-FM22-060	HSK-A 63	22	60	19	40
HSKA-063-FM22-100	HSK-A 63	22	100	19	40
HSKA-063-FM27-060	HSK-A 63	27	60	21	48
HSKA-063-FM27-100	HSK-A 63	27	100	21	48
HSKA-063-FM32-060	HSK-A 63	32	60	24	58
HSKA-063-FM32-100	HSK-A 63	32	100	24	58
HSKA-063-FM40-070	HSK-A 63	40	70	27	70
HSKA-080-FM16-060	HSK-A 80	16	60	17	32
HSKA-080-FM22-060	HSK-A 80	22	60	19	40
HSKA-080-FM27-060	HSK-A 80	27	60	21	48
HSKA-080-FM32-060	HSK-A 80	32	60	24	58
HSKA-080-FM40-070	HSK-A 80	40	70	27	70

Accessories: See Section 5



WRENCH DIN 6368

# E.W. Equipment

## HSK-A DIN 6381 FORM A

Shell Mill Adaptors DIN 6357 for cutters with driving slot

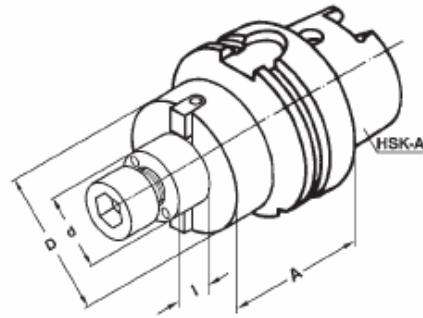

PART NUMBER	HSK	d	A	l1	D
HSKA-050-SM16-050	HSK-A 50	16	50	17	38
HSKA-050-SM22-060	HSK-A 50	22	60	19	48
HSKA-050-SM27-060	HSK-A 50	27	60	21	58
HSKA-050-SM32-060	HSK-A 50	32	60	24	78
HSKA-063-SM16-050	HSK-A 63	16	50	17	38
HSKA-063-SM16-100	HSK-A 63	16	100	17	38
HSKA-063-SM22-050	HSK-A 63	22	50	19	48
HSKA-063-SM22-100	HSK-A 63	22	100	19	48
HSKA-063-SM27-060	HSK-A 63	27	60	21	58
HSKA-063-SM27-100	HSK-A 63	27	100	21	58
HSKA-063-SM32-060	HSK-A 63	32	60	24	78
HSKA-063-SM32-100	HSK-A 63	32	100	24	78
HSKA-063-SM40-060	HSK-A 63	40	60	27	88
HSKA-063-SM40-100	HSK-A 63	40	100	27	88
HSKA-080-SM22-050	HSK-A 80	22	50	19	48
HSKA-080-SM27-050	HSK-A 80	27	50	21	58
HSKA-080-SM32-060	HSK-A 80	32	60	24	78
HSKA-080-SM40-060	HSK-A 80	40	60	27	88

# E.W. Equipment

## HSK-A DIN 6381 FORM A

Shell Mill Adaptors DIN 6357 for cutters with driving slot

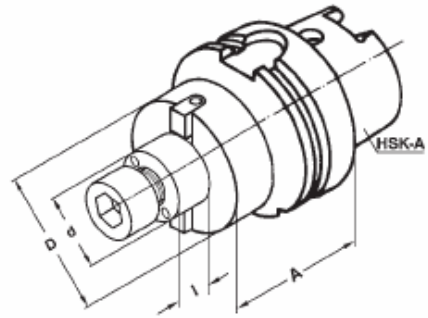

PART NUMBER	HSK	d	A	l1	D
HSKA-100-SM22-050	HSK-A 100	22	50	17	38
HSKA-100-SM27-050	HSK-A 100	27	50	19	48
HSKA-100-SM32-050	HSK-A 100	32	50	21	58
HSKA-100-SM40-060	HSK-A 100	40	60	24	78
HSKA-100-SM60-070	HSK-A 100	60	70	40	130

# E.W. Equipment

## HSK-A DIN 6381 FORM A Morse Taper Adaptors DIN 6383

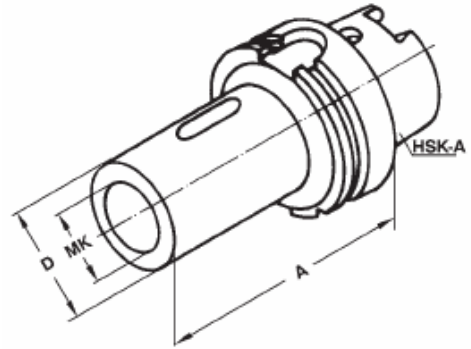

PART NUMBER	HSK	MK	A	D
HSKA-050-MT01-100	HSK-A 50	1	100	25
HSKA-050-MT02-120	HSK-A 50	2	120	32
HSKA-050-MT03-140	HSK-A 50	3	140	40

HSKA-063-MT01-100	HSK-A 63	1	100	25
HSKA-063-MT02-120	HSK-A 63	2	120	32
HSKA-063-MT03-140	HSK-A 63	3	140	40
HSKA-063-MT04-160	HSK-A 63	4	160	48

HSKA-080-MT01-110	HSK-A 80	1	110	25
HSKA-080-MT02-120	HSK-A 80	2	120	32
HSKA-080-MT03-150	HSK-A 80	3	150	40
HSKA-080-MT04-170	HSK-A 80	4	170	48

HSKA-100-MT01-110	HSK-A 100	1	110	25
HSKA-100-MT02-120	HSK-A 100	2	120	32
HSKA-100-MT03-150	HSK-A 100	3	150	40
HSKA-100-MT04-170	HSK-A 100	4	170	48
HSKA-100-MT05-200	HSK-A 100	5	200	63

# E.W. Equipment

## HSK-A DIN 6381 FORM A

Quick-Change Tapping Heads with length compensation

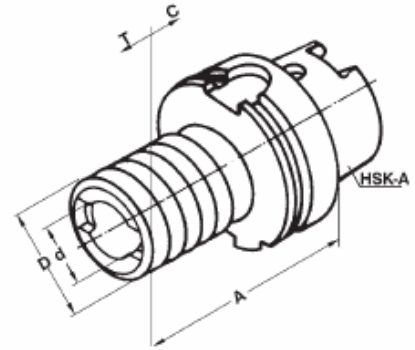

PART NUMBER	HSK	CAPACITY	A	D	d	C	T
HSKA-050-TH01-072TC	HSK-A 50	M3 - M14	72	38	19	7	7
HSKA-050-TH02-110TC	HSK-A 50	M5 - M22	110	54	31	12	12
HSKA-063-TH01-072TC	HSK-A 63	M3 - M14	72	38	19	7	7
HSKA-063-TH02-110TC	HSK-A 63	M5 - M22	110	54	31	12	12
HSKA-100-TH01-080TC	HSK-A 100	M3 - M14	80	38	19	7	7
HSKA-100-TH02-110TC	HSK-A 100	M5 - M22	110	54	31	12	12

Accessories: See Section 5



TAP ADAPTORS

# E.W. Equipment

## HSK-A DIN 6381 FORM A

Quick-Change Tapping Heads without length compensation (Rigid)

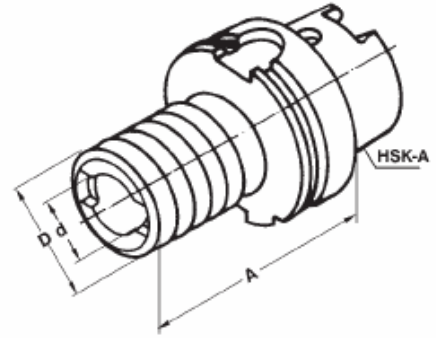

PART NUMBER	HSK	CAPACITY	A	D	d
HSKA-050-TH01-065RG	HSK-A 50	M3 - M14	65	38	19
HSKA-050-TH02-100RG	HSK-A 50	M5 - M22	100	54	31
HSKA-063-TH01-065RG	HSK-A 63	M3 - M14	65	38	19
HSKA-063-TH02-100RG	HSK-A 63	M5 - M22	100	54	31
HSKA-100-TH01-073RG	HSK-A 100	M3 - M14	73	38	19
HSKA-100-TH02-090RG	HSK-A 100	M5 - M22	90	54	31

Accessories: See Section 5



TAP ADAPTORS

# E.W. Equipment

## HSK-A DIN 6381 FORM A Hydraulic Chucks

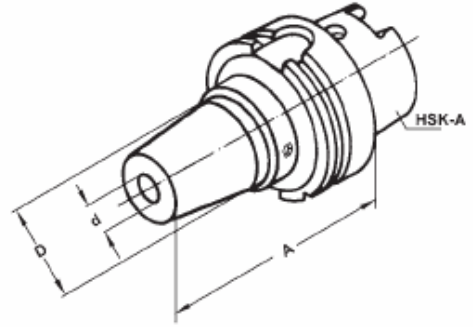

PART NUMBER	HSK	d	A	D
HSKA-040-HD06-070	HSK-A 40	6	70	34
HSKA-040-HD08-070	HSK-A 40	8	70	34
HSKA-040-HD10-075	HSK-A 40	10	75	34
HSKA-040-HD12-080	HSK-A 40	12	80	34
HSKA-050-HD06-070	HSK-A 50	6	70	40
HSKA-050-HD08-070	HSK-A 50	8	70	40
HSKA-050-HD10-075	HSK-A 50	10	75	40
HSKA-050-HD12-085	HSK-A 50	12	85	40
HSKA-050-HD14-085	HSK-A 50	14	85	40
HSKA-050-HD16-090	HSK-A 50	16	90	42
HSKA-050-HD18-090	HSK-A 50	18	90	42
HSKA-050-HD20-090	HSK-A 50	20	90	42

Accessories: See Section 5

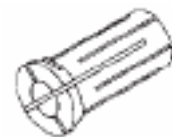

REDUCING SLEEVES

4.17

# E.W. Equipment

## HSK-A DIN 6381 FORM A Hydraulic Chucks

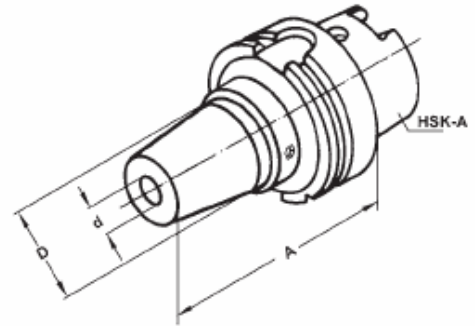

PART NUMBER	HSK	d	A	D
HSKA-063-HD06-070	HSK-A 63	6	70	50
HSKA-063-HD08-070	HSK-A 63	8	70	50
HSKA-063-HD10-080	HSK-A 63	10	80	50
HSKA-063-HD12-085	HSK-A 63	12	85	50
HSKA-063-HD14-085	HSK-A 63	14	85	50
HSKA-063-HD16-090	HSK-A 63	16	90	50
HSKA-063-HD18-090	HSK-A 63	18	90	50
HSKA-063-HD20-090	HSK-A 63	20	90	50
HSKA-063-HD25-110	HSK-A 63	25	110	53
HSKA-063-HD32-125	HSK-A 63	32	125	53

Accessories: See Section 5

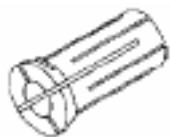

REDUCING SLEEVES

# E.W. Equipment

## HSK-A DIN 6381 FORM A Hydraulic Chucks

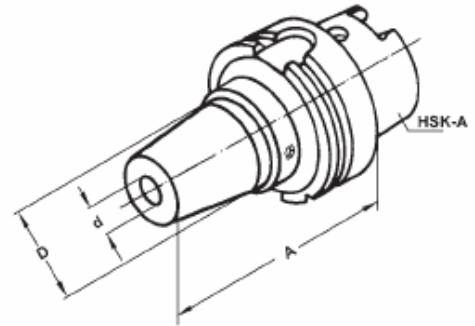

PART NUMBER	HSK	d	A	D
HSKA-080-HD06-070	HSK-A 80	6	70	50
HSKA-080-HD08-070	HSK-A 80	8	70	50
HSKA-080-HD10-080	HSK-A 80	10	80	50
HSKA-080-HD12-085	HSK-A 80	12	85	50
HSKA-080-HD14-085	HSK-A 80	14	85	50
HSKA-080-HD16-095	HSK-A 80	16	95	50
HSKA-080-HD18-095	HSK-A 80	18	95	50
HSKA-080-HD20-095	HSK-A 80	20	95	50
HSKA-080-HD25-115	HSK-A 80	25	115	57
HSKA-080-HD32-125	HSK-A 80	32	125	67

Accessories: See Section 5

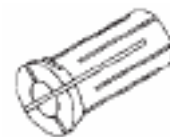

REDUCING SLEEVES

4.19

# E.W. Equipment

## HSK-A DIN 6381 FORM A Hydraulic Chucks

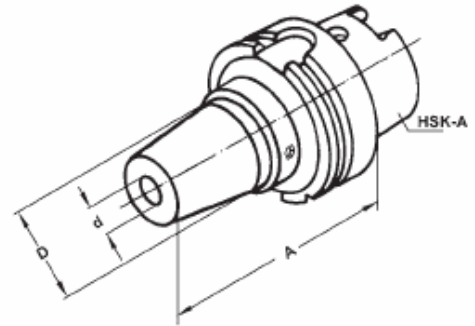

PART NUMBER	HSK	d	A	D
HSKA-100-HD06-085	HSK-A 100	6	85	50
HSKA-100-HD08-085	HSK-A 100	8	85	50
HSKA-100-HD10-090	HSK-A 100	10	90	50
HSKA-100-HD12-095	HSK-A 100	12	95	50
HSKA-100-HD14-095	HSK-A 100	14	95	50
HSKA-100-HD16-100	HSK-A 100	16	100	50
HSKA-100-HD18-100	HSK-A 100	18	100	50
HSKA-100-HD20-105	HSK-A 100	20	105	50
HSKA-100-HD25-115	HSK-A 100	25	115	57
HSKA-100-HD32-120	HSK-A 100	32	120	67

Accessories: See Section 5

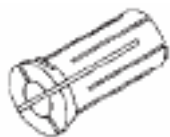

REDUCING SLEEVES

4.20

# E.W.Equipment

## HSK-A DIN 6381 FORM A

Boring Bar Blanks for the production of special tools

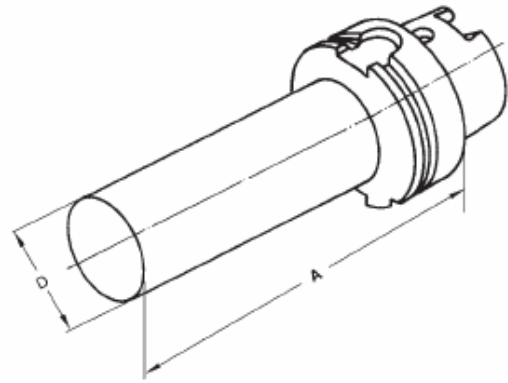

PART NUMBER	HSK	D	A
HSKA-032-BB32.5-100	HSK-A 32	32.5	100
HSKA-040-BB40.5-160	HSK-A 40	40.5	160
HSKA-050-BB50.5-200	HSK-A 50	50.5	200
HSKA-063-BB63.5-250	HSK-A 63	63.5	250
HSKA-080-BB80.5-250	HSK-A 80	80.5	250
HSKA-100-BB95.5-250	HSK-A 100	95.5	250

# E.W. Equipment

## HSK-A DIN 6381 FORM A NC-Drill Chucks for left and right rotation

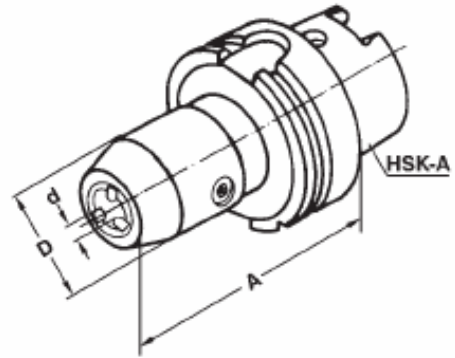

PART NUMBER	HSK	CENTRE COOLANT	d CAPACITY	A	D
HSKA-050-DC13-116	HSK-A 50	NO	1-13	116	50
HSKA-050-DC16-116	HSK-A 50	NO	3-16	116	57
HSKA-063-DC13-104	HSK-A 63	NO	1-13	104	50
HSKA-063-DC16-104	HSK-A 63	NO	3-16	104	57
HSKA-063-DC13-104CC	HSK-A 63	YES	1-13	104	50
HSKA-063-DC16-104CC	HSK-A 63	YES	3-16	104	57
HSKA-080-DC13-109	HSK-A 80	NO	1-13	109	50
HSKA-080-DC16-109	HSK-A 80	NO	3-16	109	57
HSKA-080-DC13-109CC	HSK-A 80	YES	1-13	109	50
HSKA-080-DC16-109CC	HSK-A 80	YES	3-16	109	57
HSKA-100-DC13-111	HSK-A 100	NO	1-13	111	50
HSKA-100-DC16-111	HSK-A 100	NO	3-16	111	57
HSKA-100-DC13-111CC	HSK-A 100	YES	1-13	111	50
HSKA-100-DC16-111CC	HSK-A 100	YES	3-16	111	57

Includes:  
Hexagon wrench.

# E.W. Equipment

## HSK-A DIN 6381 Delivery Unit for Coolant

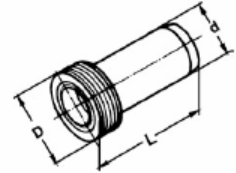

PART NUMBER	HSK	D	d	L
HSK-032-CT	HSK 32	M10x1	6	26
HSK-040-CT	HSK 40	M12x1	8	29.5
HSK-050-CT	HSK 50	M16x1	10	33
HSK-063-CT	HSK 63	M18x1	12	34.5
HSK-080-CT	HSK 80	M20x1.5	14	40
HSK-100-CT	HSK 100	M24x1.5	16	44

## HSK-A DIN 6381 Socket Wrench for Connection

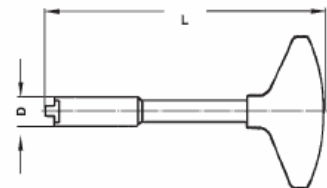

PART NUMBER	HSK	D	L
HSK-032-SW	HSK 32	8.5	115
HSK-040-SW	HSK 40	10.5	115
HSK-050-SW	HSK 50	14.5	115
HSK-063-SW	HSK 63	16.5	136
HSK-080-SW	HSK 80	18.5	136
HSK-100-SW	HSK 100	22	136