

E.W. Equipment

Tooling Catalogue



JIS B 6399 (MAS 403 BT) AD/B TOOLHOLDERS

11 Worcester Road, Cheadle Hulme, Cheadle, Cheshire, SK8 5NW
Tel: 0161 485 8730 Fax: 0161 485 6745
email: sales@ewequipment.co.uk web: www.ewequipment.co.uk

SECTION 3

JIS B 6339 (MAS 403 BT) TOOLHOLDERS

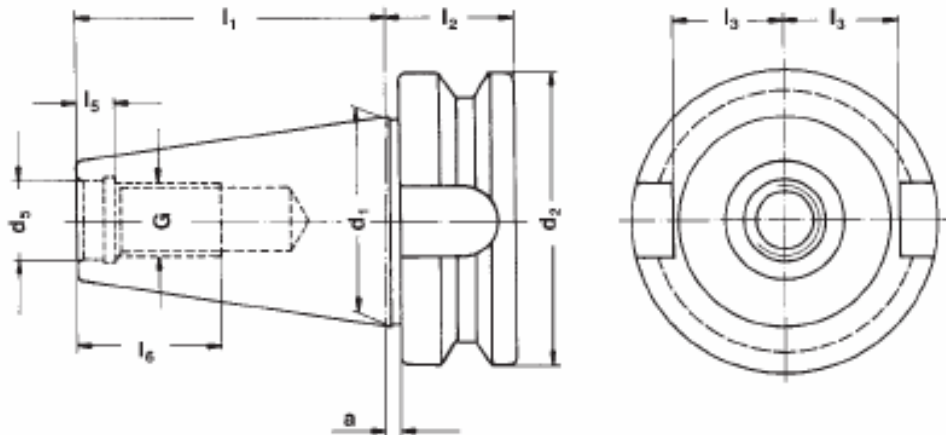

Pre-balanced G6,3 8000 min -1
G2,5 Fine Balancing available at extra cost

SK	d1	G	d5	d2	a	l1	l2	l3	l5	l6	E1	D9
30	31,75	M12	12,5	46	2	48,4	22	16,3	7,0	24	-	-
40	44,45	M16	17,0	63	2	65,4	27	22,5	8,2	32	27	M4
50	69,85	M24	25,0	100	3	101,8	38	35,3	11,0	47	42	M6

JIS B 6399 (MAS 403 BT)FORM AD/B

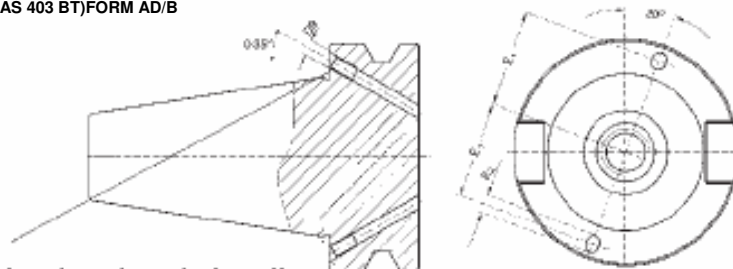

With internal coolant through the collar
Delivered with headless screws in closed position

- Material:** Alloyed case hardened steel, tensile strength in the core of min. 800 N/mm²
Case hardened HRC 60 ± 2 (HV 700 ± 50), hardening depth 0,8 mm ± 0,2 mm, black-finished
- Type AD/B:** Delivery in form AD, type B closed with a releasable headless screw
- Accuracy:** Cone angle – tolerance exactness < AT 3 according to DIN 7187 and DIN 2080
Max. run out inaccuracy < 0,005 mm

3.01

E.W. Equipment

JIS B 6399 (MAS 403 BT) AD & AD/B Collet Chucks for Collets DIN 6499 ER

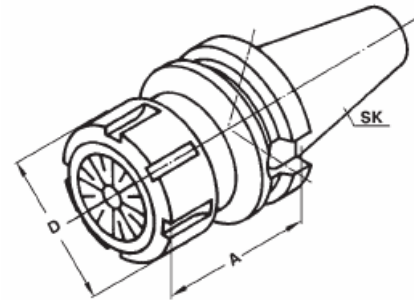

PART NUMBER	SK	FORM	CAPACITY	A	D
BT30-ER16-070	30	AD	ER16 1-10	70	32
BT30-ER16-100	30	AD	ER16 1-10	100	32
BT30-ER25-070	30	AD	ER25 2-16	70	42
BT30-ER32-070	30	AD	ER32 2-20	70	50
BT30-ER40-070	30	AD	ER40 3-26	70	63
BT40-ER16-063	40	AD/B	ER16 1-10	63	32
BT40-ER16-100	40	AD/B	ER16 1-10	100	32
BT40-ER16-160	40	AD/B	ER16 1-10	160	32
BT40-ER25-060	40	AD/B	ER25 2-16	60	42
BT40-ER32-070	40	AD/B	ER32 2-20	70	50
BT40-ER32-100	40	AD/B	ER32 2-20	100	50
BT40-ER40-080	40	AD/B	ER40 3-26	80	63
BT50-ER32-070	50	AD	ER32 2-20	70	50
BT50-ER40-080	50	AD	ER40 3-26	80	63

Accessories: See Section 5



ER-COLLETS

ER-WRENCH

E.W. Equipment

JIS B 6399 (MAS 403 BT) AD & AD/B

End Mill Holders DIN 6359 for Weldon Type End Mills DIN 1835-B

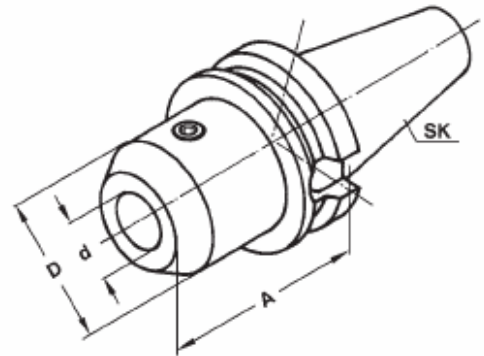

PART NUMBER	SK	FORM	d	A	D
BT30-WE06-050	30	AD	6	50	25
BT30-WE08-050	30	AD	8	50	28
BT30-WE10-050	30	AD	10	50	35
BT30-WE12-050	30	AD	12	50	42
BT30-WE14-050	30	AD	14	50	44
BT30-WE16-063	30	AD	16	63	48
BT30-WE18-063	30	AD	18	63	50
BT30-WE20-063	30	AD	20	63	52

BT40-WE06-050	40	AD/B	6	50	25
BT40-WE06-100	40	AD/B	6	100	25
BT40-WE08-050	40	AD/B	8	50	28
BT40-WE08-100	40	AD/B	8	100	28
BT40-WE10-063	40	AD/B	10	63	35
BT40-WE10-100	40	AD/B	10	100	35
BT40-WE12-063	40	AD/B	12	63	42
BT40-WE12-100	40	AD/B	12	100	42
BT40-WE14-063	40	AD/B	14	63	44
BT40-WE14-100	40	AD/B	14	100	44

E.W. Equipment

JIS B 6399 (MAS 403 BT) AD & AD/B

End Mill Holders DIN 6359 for Weldon Type End Mills DIN 1835-B

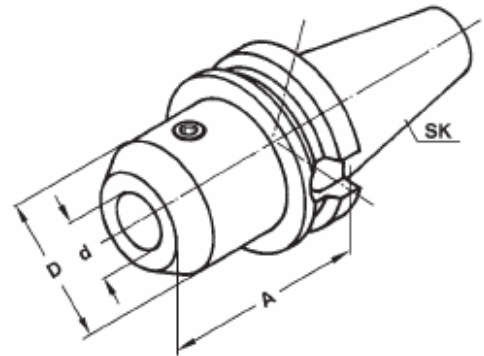

PART NUMBER	SK	FORM	d	A	D
BT40-WE16-035	40	AD	16	35	45
BT40-WE16-063	40	AD/B	16	63	48
BT40-WE16-100	40	AD/B	16	100	48
BT40-WE18-063	40	AD/B	18	63	50
BT40-WE18-100	40	AD/B	18	100	50
BT40-WE20-035	40	AD	20	35	45
BT40-WE20-063	40	AD/B	20	63	52
BT40-WE20-100	40	AD/B	20	100	52
BT40-WE25-035	40	AD	25	35	55
BT40-WE25-090	40	AD/B	25	90	65
BT40-WE32-065	40	AD	32	65	50
BT40-WE32-100	40	AD/B	32	100	72
BT40-WE40-120	40	AD/B	40	120	80

E.W.Equipment

JIS B 6399 (MAS 403 BT) AD

End Mill Holders DIN 6359 for Weldon Type End Mills DIN 1835-B

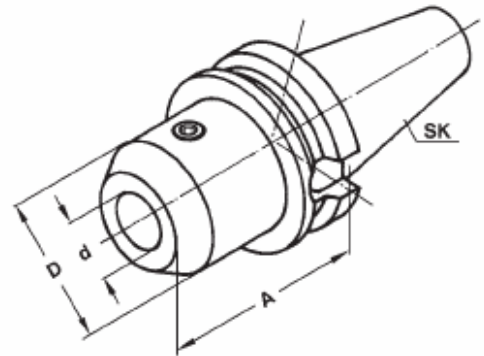

PART NUMBER	SK	d	A	D
BT50-WE06-063	50	6	63	25
BT50-WE08-063	50	8	63	28
BT50-WE10-063	50	10	63	35
BT50-WE12-080	50	12	80	42
BT50-WE14-080	50	14	80	44
BT50-WE16-080	50	16	80	48
BT50-WE18-080	50	18	80	50
BT50-WE20-080	50	20	80	52
BT50-WE25-100	50	25	100	65
BT50-WE32-105	50	32	105	72
BT50-WE40-110	50	40	110	80

E.W. Equipment

JIS B 6399 (MAS 403 BT) AD & AD/B

End Mill Holders DIN 6359 with coolant channel
for Weldon Type End Mills DIN 1835-B

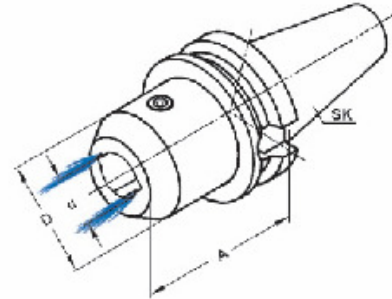

PART NUMBER	SK	FORM	d	A	D
BT40-WE06-050-CC	40	AD/B	6	50	25
BT40-WE08-050-CC	40	AD/B	8	50	28
BT40-WE10-063-CC	40	AD/B	10	63	35
BT40-WE12-063-CC	40	AD/B	12	63	42
BT40-WE14-063-CC	40	AD/B	14	63	44
BT40-WE16-063-CC	40	AD/B	16	63	48
BT40-WE18-063-CC	40	AD/B	18	63	50
BT40-WE20-063-CC	40	AD/B	20	63	52
BT40-WE25-090-CC	40	AD/B	25	90	65
BT40-WE32-100-CC	40	AD/B	32	100	72
BT40-WE40-120-CC	40	AD/B	40	120	80

BT50-WE06-063-CC	50	AD	6	63	25
BT50-WE08-063-CC	50	AD	8	63	28
BT50-WE10-063-CC	50	AD	10	63	35
BT50-WE12-080-CC	50	AD	12	80	42
BT50-WE14-080-CC	50	AD	14	80	44
BT50-WE16-080-CC	50	AD	16	80	48
BT50-WE18-080-CC	50	AD	18	80	50
BT50-WE20-080-CC	50	AD	20	80	52
BT50-WE25-100-CC	50	AD	25	100	65
BT50-WE32-105-CC	50	AD	32	105	72
BT50-WE40-110-CC	50	AD	40	110	80

E.W. Equipment

JIS B 6399 (MAS 403 BT) AD & AD/B

Whistle Notch Holders DIN 6359 for End Mills DIN 1835-E

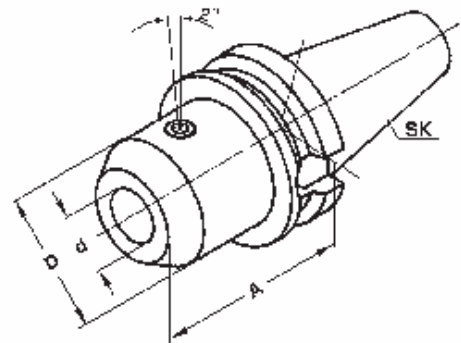

PART NUMBER	SK	FORM	d	A	D
BT40-WN06-050	40	AD/B	6	50	25
BT40-WN08-050	40	AD/B	8	50	28
BT40-WN10-063	40	AD/B	10	63	35
BT40-WN12-063	40	AD/B	12	63	42
BT40-WN14-063	40	AD/B	14	63	44
BT40-WN16-063	40	AD/B	16	63	48
BT40-WN18-063	40	AD/B	18	63	50
BT40-WN20-063	40	AD/B	20	63	52
BT40-WN25-090	40	AD/B	25	90	65
BT40-WN32-100	40	AD/B	32	100	72
BT40-WN40-120	40	AD/B	40	120	80

BT50-WN06-063	50	AD	6	63	25
BT50-WN08-063	50	AD	8	63	28
BT50-WN10-063	50	AD	10	63	35
BT50-WN12-080	50	AD	12	80	42
BT50-WN14-080	50	AD	14	80	44
BT50-WN16-080	50	AD	16	80	48
BT50-WN18-080	50	AD	18	80	50
BT50-WN20-080	50	AD	20	80	52
BT50-WN25-100	50	AD	25	100	65
BT50-WN32-105	50	AD	32	105	72
BT50-WN40-110	50	AD	40	110	80

E.W. Equipment

JIS B 6399 (MAS 403 BT) AD Combi Shell Mill Adaptors DIN 6358

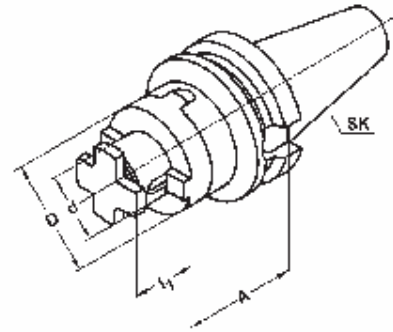

PART NUMBER	SK	d	A	l1	D
BT30-FM16-045	30	16	45	17	32
BT30-FM22-047	30	22	47	19	40
BT30-FM27-049	30	27	49	21	48

BT40-FM16-055	40	16	55	17	32
BT40-FM16-100	40	16	100	17	32
BT40-FM22-055	40	22	55	19	40
BT40-FM22-100	40	22	100	19	40
BT40-FM27-055	40	27	55	21	48
BT40-FM27-100	40	27	100	21	48
BT40-FM32-060	40	32	60	24	58
BT40-FM32-100	40	32	100	24	58
BT40-FM40-060	40	40	60	27	70
BT40-FM40-100	40	40	100	27	70

BT50-FM16-070	50	16	70	17	32
BT50-FM22-070	50	22	70	19	40
BT50-FM27-070	50	27	70	21	48
BT50-FM32-070	50	32	70	24	58
BT50-FM40-070	50	40	70	27	70

Accessories: See Section 5



WRENCH DIN 6368

Includes:
Feather key, drive ring and draw-in bolt.

3.08

E.W. Equipment

JIS B 6399 (MAS 403 BT) AD & AD/B Shell Mill Adaptors DIN 6357

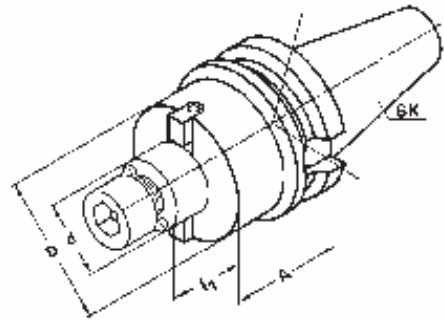

PART NUMBER	SK	FORM	d	A	l1	D
BT30-SM16-040	30	AD	16	40	17	38
BT30-SM22-040	30	AD	22	40	19	48
BT30-SM27-040	30	AD	27	40	21	58
BT30-SM32-050	30	AD	32	50	24	78
BT40-SM16-040	40	AD/B	16	40	17	38
BT40-SM22-040	40	AD/B	22	40	19	48
BT40-SM27-040	40	AD/B	27	40	21	58
BT40-SM32-050	40	AD/B	32	50	24	78
BT40-SM40-050	40	AD/B	40	50	27	88
BT50-SM22-040	50	AD	22	40	19	48
BT50-SM27-040	50	AD	27	40	21	58
BT50-SM32-050	50	AD	32	50	24	78
BT50-SM40-050	50	AD	40	50	27	88
BT50-SM60-080	50	AD	60	80	40	129

Includes:

Drive and cruciform screw

d = 40 & d = 60 have additional screw holes in compliance with DIN 2079

3.09

Accessories: See Section 5



WRENCH DIN 6368

E.W. Equipment

JIS B 6399 (MAS 403 BT) AD & AD/B Morse Taper Adaptors DIN 6383

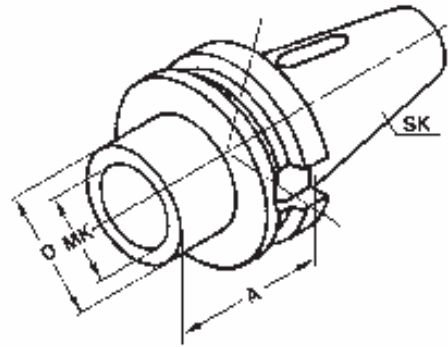

PART NUMBER	SK	FORM	MK	A	D
BT30-MT01-045	30	AD	1	45	25
BT30-MT02-060	30	AD	2	60	32
BT30-MT03-075	30	AD	3	75	40
BT40-MT01-050	40	AD/B	1	50	25
BT40-MT02-050	40	AD/B	2	50	32
BT40-MT03-070	40	AD/B	3	70	40
BT40-MT04-095	40	AD/B	4	95	48
BT50-MT01-045	50	AD	1	45	25
BT50-MT02-060	50	AD	2	60	32
BT50-MT03-065	50	AD	3	65	40
BT50-MT04-095	50	AD	4	95	48
BT50-MT05-105	50	AD	5	105	63

E.W. Equipment

JIS B 6399 (MAS 403 BT) AD Reduction Adaptors

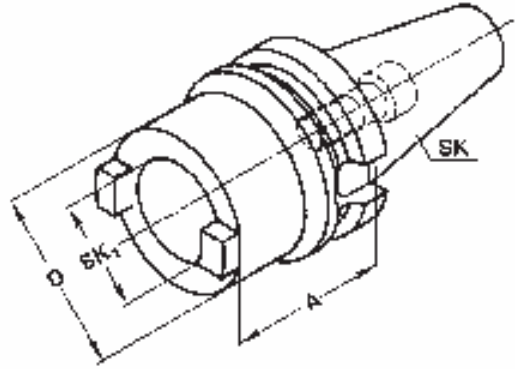

PART NUMBER	SK	SK1	A	D
BT40-RA30-060	40	30	60	63
BT40-DA40-100	40	40	100	63
BT50-RA40-070	50	40	70	70
BT50-RA50-120	50	50	120	97

Includes:
Built in screw for shortened taper tools
& additional screw for DIN 2080 tools.

3.11

E.W. Equipment

JIS B 6399 (MAS 403 BT) AD

Boring Bar Blanks for the production of special tools

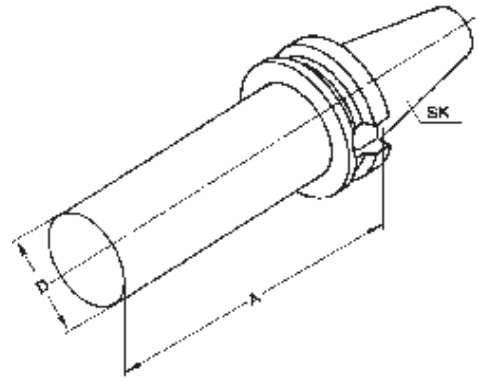

PART NUMBER	SK	D	A
BT40-BB63-250	40	63	250
BT50-BB97-315	50	97	315

E.W. Equipment

JIS B 6399 (MAS 403 BT) AD Drill Chuck Adaptors DIN 238

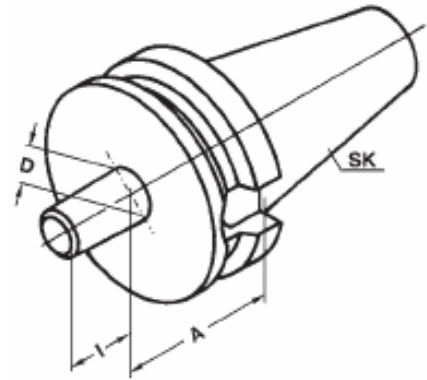

PART NUMBER	SK	D	A	I
BT30-B12-025	30	B12	25	18.5
BT30-B16-025	30	B16	25	24
BT40-B12-025	40	B12	25	18.5
BT40-B16-025	40	B16	25	24
BT40-B18-032	40	B18	32	32
BT50-B16-032	50	B16	32	24
BT50-B18-032	50	B18	32	32

E.W. Equipment

JIS B 6399 (MAS 403 BT) AD & AD/B NC-Drill Chucks for left and right rotation

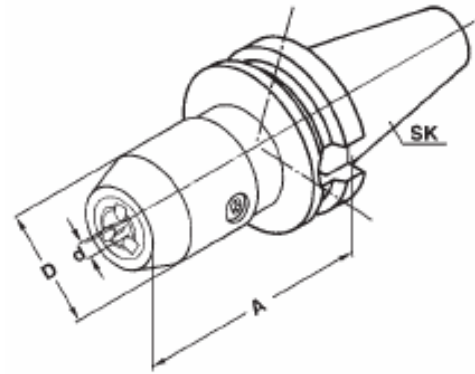

PART NUMBER	SK	FORM	d CAPACITY	A	D
BT30-DC08-074A	30	AD	0.5 - 8	74	36
BT30-DC13-096A	30	AD	1.0 - 13	96	50
BT40-DC08-078A	40	AD	0.5 - 8	78	36
BT40-DC13-098A	40	AD	1.0 - 13	98	50
BT40-DC16-098A	40	AD	3.0 - 16	98	57
BT40-DC13-098B	40	AD/B	1.0 - 13	98	50
BT40-DC16-098B	40	AD/B	3.0 - 16	98	57
BT50-DC13-110A	50	AD	1.0 - 13	110	50
BT50-DC16-110A	50	AD	3.0 - 16	110	57

Includes:
Hexagon wrench.

E.W. Equipment

JIS B 6399 (MAS 403 BT) AD

Quick-Change Tapping Heads with length compensation

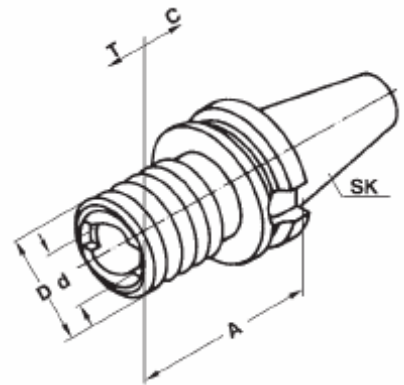

PART NUMBER	SK	CAPACITY	A	D	d	C	T
BT30-TH01-062TC	30	M3 - M14	62	38	19	7	7
BT30-TH02-095TC	30	M5 - M22	95	54	31	12	12
BT40-TH01-065TC	40	M3 - M14	65	38	19	7	7
BT40-TH02-093TC	40	M5 - M22	93	54	31	12	12
BT40-TH03-126TC	40	M14 - M36	126	78	48	17.5	17.5
BT50-TH01-080TC	50	M3 - M14	80	38	19	7	7
BT50-TH02-100TC	50	M5 - M22	100	54	31	12	12
BT50-TH03-142TC	50	M14 - M36	142	78	48	17.5	17.5

Accessories: See Section 5



TAP ADAPTORS

E.W. Equipment

JIS B 6399 (MAS 403 BT) AD

Quick-Change Tapping Heads without length compensation (Rigid)

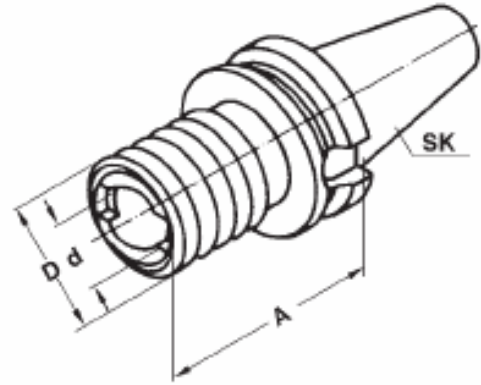

PART NUMBER	SK	CAPACITY	A	D	d
BT30-TH01-066RG	30	M3 - M14	66	38	19
BT30-TH02-080RG	30	M5 - M22	80	54	31
BT40-TH01-065RG	40	M3 - M14	65	38	19
BT40-TH02-093RG	40	M5 - M22	93	54	31
BT40-TH03-126RG	40	M14 - M36	126	78	48
BT50-TH01-080RG	50	M3 - M14	80	38	19
BT50-TH02-100RG	50	M5 - M22	100	54	31
BT50-TH03-142RG	50	M14 - M36	142	78	48

Accessories: See Section 5



TAP ADAPTORS

E.W. Equipment

JIS B 6399 (MAS 403 BT) AD Hydraulic Chucks

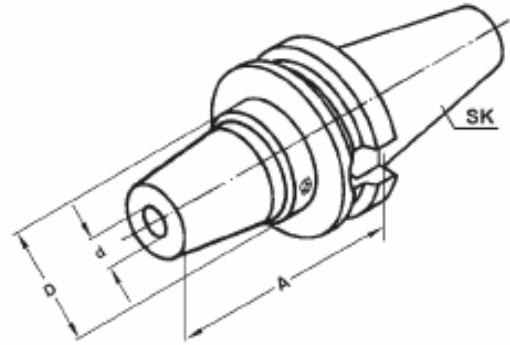

PART NUMBER	SK	d	A	D
BT40-HD06-090	40	6	90	49.5
BT40-HD08-090	40	8	90	49.5
BT40-HD10-090	40	10	90	49.5
BT40-HD12-090	40	12	90	49.5
BT40-HD14-090	40	14	90	49.5
BT40-HD16-090	40	16	90	49.5
BT40-HD18-090	40	18	90	49.5
BT40-HD20-090	40	20	90	49.5
BT40-HD25-090	40	25	90	60

Accessories: See Section 5

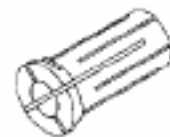

REDUCING SLEEVES

E.W. Equipment

JIS B 6399 (MAS 403 BT) AD Hydraulic Chucks

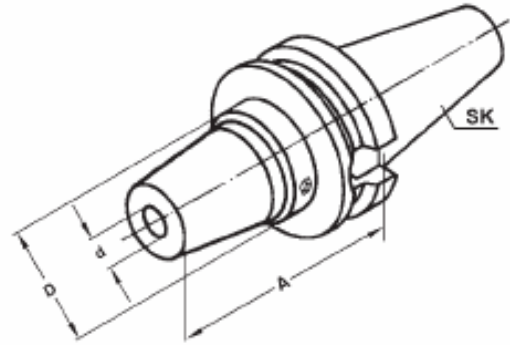

PART NUMBER	SK	d	A	D
BT50-HD06-110	50	6	110	49.5
BT50-HD08-110	50	8	110	49.5
BT50-HD10-110	50	10	110	49.5
BT50-HD12-110	50	12	110	49.5
BT50-HD14-110	50	14	110	49.5
BT50-HD16-110	50	16	110	49.5
BT50-HD18-110	50	18	110	49.5
BT50-HD20-110	50	20	110	49.5
BT50-HD25-115	50	25	115	55
BT50-HD32-115	50	32	115	70

Accessories: See Section 5

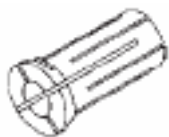

REDUCING SLEEVES

3.18